

Railway applications

- Relays
- Time relays
- Monitoring relays
- Sockets



Reliable and Safe Solutions for Railway and Transportation Applications

Solutions for the transport market need to guarantee safety, security and comfort. The applications are expected to last a long time under challenging conditions. Be it for high-speed trains, metros, subways or other rail vehicles – in tunnels, on bridges, in train stations, airports, on the open track, or in harbor facilities, the Comat Releco Group has the right solution for different kind of applications. We offer a wide range of relays, control and monitoring devices that are developed in compliance with the European Railway Standard EN 50155 (including also EN 61373, EN 45545 and NF F 16-101/102).

The EN 50155 standard applies for all electronic devices such as command, control, protection units, as well as power supplies, which are used in the transportation market. It applies either to the accumulator battery side or also the low-voltage power supply part of the vehicle.

Regarding fire protection, the products offered in this brochure are manufactured in accordance with standard NF F 16-101/102.

A table at the last page of this brochure shows the overview of the products and the standards they comply with. Individual declarations of conformity are available on demand. Please do not hesitate to contact us for any further questions or comments.

Comat AG
Bernstrasse 4
3076 Worb
Switzerland

www.comat.ch
info@comat.ch

Index

1. Relays		Page 3
Long life series with single contacts	C31D/R	4
Long life series with twin contacts	C32D/R	5
Standard relay	R3-N3x	6
Standard relay	R4-A4x	7
Miniature relay	R7-A2x	8
Miniature relay	R7-T2x	9
Interface relay	CINT-21	10
Interface relay	CINT-22	11
Interface relay	CINT-25	12
Interface relay	CINT-61	13
Interface relay	CINT-62	14
Interface relay	CINT-63	15
Signal relay	C203.06R	16
Power relay	RIC20-x	17
Power relay	RIC25-x	18

2. Time Relays		Page 19
Time functions		20
Multifunction Timer, relay change-over	CIM1R	21
Multifunction Timer, solid-state AC	CIM12R	22
Multifunction Timer, solid-state DC	CIM13R	23
Multifunction Timer, relay change-over	CIM2R	24
Multifunction Timer, solid-state AC	CIM22R	25
Multifunction Timer, solid-state DC	CIM23R	26
Multifunction Timer, relay change-over	CIM3R	27
Multifunction Timer, semi-conductor AC	CIM32R	28
Multifunction Timer, semi-conductor DC	CIM33R	29
CT-System: Plug-in time modules	CT32R, CT33R, CT36R	30
Plug-in time relays	CT32...R, CT33...R, CT36...R	31

3. Monitoring Relays		Page 33
1-phase monitoring	MRU11R	34
3-phase monitoring	MRU32R	35
1-phase monitoring	MRI11R	36
3-phase monitoring	MRI32R	37
1-phase monitoring	MRM11R	38
3-phase monitoring	MRM32R	39
CT-System: Plug-in current monitoring modules	CT512R, CT515R, CT516R	40
Plug-in current monitoring set	CT512...R, CT515...R, CT516...R	42
Plug-in DC voltage monitoring module	CT524R	41
Plug-in DC voltage monitoring set	CT524...R	42
Insulation monitoring	ESU-D2R	43

4. Sockets		Page 45
Socket for 11 pin relays and plug-in modules	C11A (for relays: C31D/R, C32D/R, R3-N3)	46
Socket for 11 pin relays and plug-in modules	C12B0 (for relays: C31D/R, C32D/R, R3-N3)	47
Socket for 14 pin relays	CS-144 (for relays: R4-A4x)	48
Socket for miniature relays	CS-118 (for relays: R7-x)	49

1. Relays

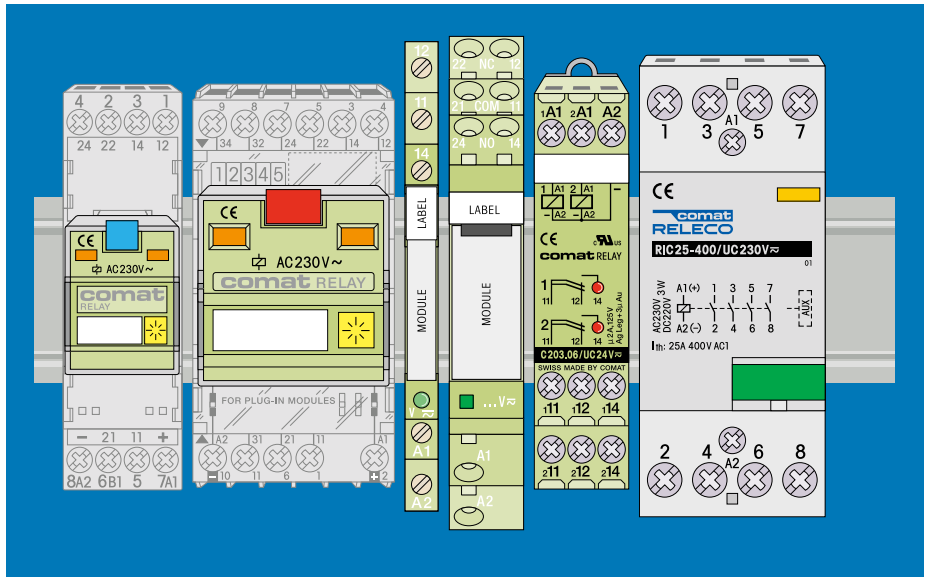

Application	Types	Output contacts	Design
11 pin plug-in, long life relay	C31D/R	10A, 250V AC-1	
11 pin plug-in, long life relay	C32D/R	6A, 250V AC-1	
11 pin plug-in, standard relay	R3-N3...	6A, 250V AC-1	
14 pin plug-in, standard relay	R4-A4...	10A, 250V AC-1	
8 pin plug-in, miniature standard relay	R7-A2...	10A, 250V AC-1	
8 pin plug-in, miniature standard relay	R7-T2...	6A, 250V AC-1	
Interface relay	CINT-21	6A, 250V AC-1	
Interface relay	CINT-22	6A, 250V AC-1	
Interface relay	CINT-25	2A, 250V AC-1	
Interface relay	CINT-61	10A, 250V AC-1	
Interface relay	CINT-62	8A, 250V AC-1	
Interface relay	CINT-63	8A, 250V AC-1	
Interface relay	C203.06	2x 2A, 125V AC-1	
Power relay	RIC20-...	20A, 230V AC-1	
Power relay	RIC25-...	25A, 230V AC-1	

Long life series with single contacts

C31D/R

11 pin plug-in relay, 3-pole, change-over contacts, according to IEC 60067

Type: C31D/R ...V

Long Life Relays for Railway application, 3 change-over contacts

Types with LED status indicator

Types with free wheeling diode

Manual actuator and mech. status indicator

Maximum contact load 10 A / 250 V AC-1

Recommended minimum contact load 10 A / 30 V DC-1

50 mA / 10 V

Contacts

Type single contact micro disconnection

Material AgCuNi

Rated current 10 A

Inrush current max. (20 ms) 40 A

Switching voltage AC-1 max. 250 V

AC load max. 2500 VA AC-1

DC load max. see Fig. 2

Coils (Values are valid at 20 °C)

Operating voltage range 0.7 ... 1.25 U_N

Nominal power DC 1.2 W

Coil Table

V _N DC	Ω	mA
24	340	70
36	780	46
72	3200	23
110	9700	11

Types with LED indicator take additional 5 ... 10 mA @ < 80 V

Insulation

Pulse (1.2 / 50 us / Dielectric strength (V rms, 1 minute)

Contact / coil - / 2.5 kV

Contact / contact - / 2.5 kV

Contact open - / 1.5 kV

General Specifications

Ambient temperature operation / storage -40 ... +70 °C / -40 ... +85 °C

Pick-up time typ. 12 ms

Release time typ. 20 ms

Bounce time NO contact typ. 3.5 ms

Mechanical life ≥ 10⁸ operations

Operating frequency at nominal load ≤ 360 operations / h

Ingress protection rating IP 40

Weight 80 g

Standard types

DC: 24, 36, 72, 110 V

C31D/R DC...V

"..." Enter the voltage for full type designation

Accessories

Socket: **C11A, C12B0**

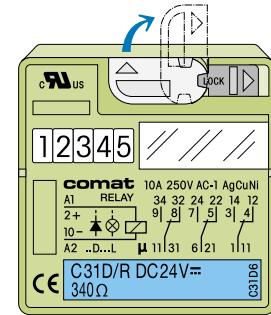

Connection diagram

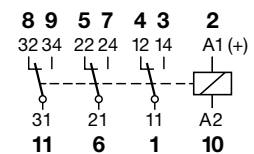

Fig. 1 AC voltage endurance

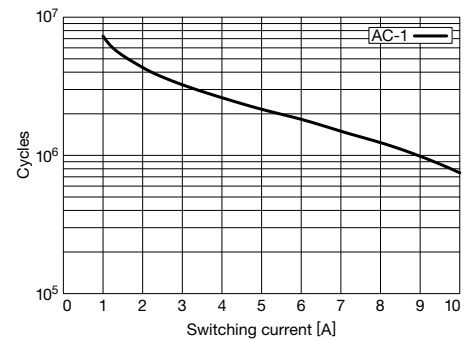
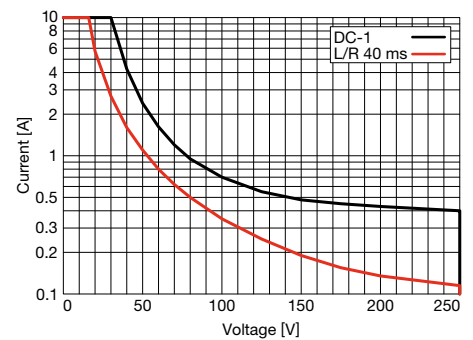
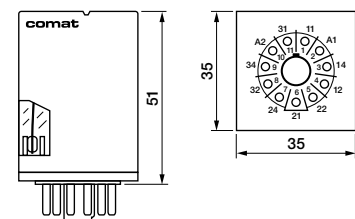

Fig. 2 DC load limit curve



Dimensions [mm]



Technical approvals, conformities

See table on page 53.

Long life series with twin contacts

C32D/R

11 pin plug-in relay, 3-pole, change-over twin contacts, according to IEC 60067

Type: C32D/R ...V

Long Life Relays for Railway application, 3 change-over twin contacts

Types with LED status indicator

Types with free wheeling diode

Manual actuator and mech. status indicator

Maximum contact load	6 A / 250 V AC-1
	6 A / 30 V DC-1
Recommended minimum contact load	10 mA / 5 V

Contacts

Type	twin contact micro disconnection
Material	AgCuNi
Rated current	6 A
Inrush current max. (20 ms)	15 A
Switching voltage AC-1 max.	250 V
AC load max.	1500 VA AC-1
DC load max.	see Fig. 2

Coils (Values are valid at 20 °C)

Operating voltage range	0.7 ... 1.25 U _N
Nominal power DC	1.2 W

Coil Table

V _N DC	Ω	mA
24	340	70
36	780	46
110	9700	11

Types with LED indicator take additional 5 ... 10 mA @ < 80 V

Insulation

Pulse (1.2 / 50 us / Dielectric strength (V rms, 1 minute)

Contact / coil	- / 2.5 kV
Contact / contact	- / 2.5 kV
Contact open	- / 1.5 kV

General Specifications

Ambient temperature operation / storage	-40 ... +70 °C / -40 ... +85 °C
Pick-up time typ.	12 ms
Release time typ.	20 ms
Bounce time NO contact typ.	3.5 ms
Mechanical life	≥ 10 ⁸ operations
Operating frequency at nominal load	≤ 360 operations / h
Ingress protection rating	IP 40
Weight	80 g

Standard types

DC: 24, 36, 110 V

C32D/R DC...V

"..." Enter the voltage for full type designation

Accessories

Socket: **C11A, C12B0**

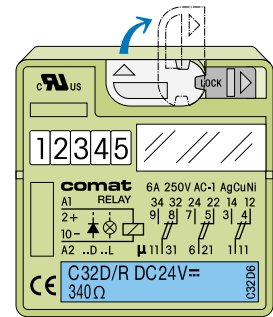

Connection diagram

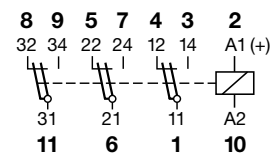

Fig. 1 AC voltage endurance

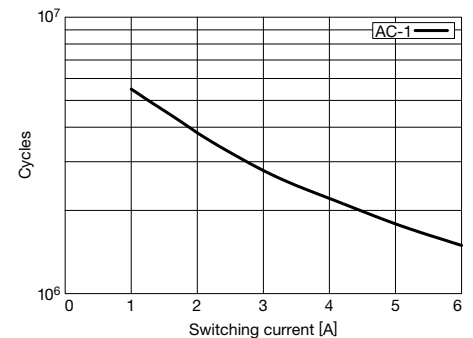
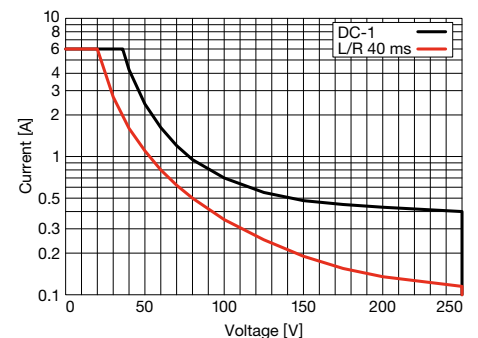
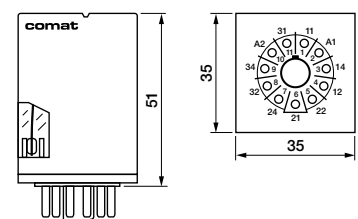

Fig. 2 DC load limit curve



Dimensions [mm]



Technical approvals, conformities

See table on page 53.

R3-N3...

11-pin plug-in relay, 3-pole, change-over contacts, according to IEC 60067



Type: R3-Nxx/...V

Relays for Railway application, 3 change-over contacts

Maximum contact load	6 A / 250 V AC-1, 6 A / 30 V DC-1
Recommended minimum contact load	10 mA / 10 V Code 4 5 mA / 5 V Code 8

Contacts

Material	Optional	Code 4	AgNi + 0.2μ Au
	Optional	Code 8	AgNi + 10μ Au
Rated current			6 A
Inrush current max. (20 ms)			15 A
Switching voltage AC-1 max.			250 V
AC load max.			see Fig. 1
DC load max.			see Fig. 2

Coil (Values are valid at 20 °C)

Coil resistance	see table; tolerance ± 10 %
Operating voltage range	0.7 ... 1.25 U _N
Nominal power	1.1 W

Coil Table

V DC	Ω	mA
24	525	46
48	2133	22
72	4844	15
110	12900	9

Insulation

Pulse (1.2 / 50 us / Dielectric strength (V rms, 1 minute)	
Contact / coil	4 kV / 2.5 kV
Contact / contact	4 kV / 2.5 kV
Contact open	1.5 kV / 1 kV

Specifications

Ambient temperature operation / storage	-25 (no ice) ... +70 °C / -40 ... +80 °C
Pick-up time / bounce time	18 ms / ≤ 3 ms
Release time / bounce time (D version)	35 ms / ≤ 1 ms
Mechanical life	> 10 millions
Ingress protection rating	IP 40
Weight	95 g

Standard types

DC: 24, 48, 72, 110 V	R3-N34/DC...V	R3-N38/DC...V
Free wheeling diode	R3-N34D/DC...V	R3-N38D/DC...V
LED	R3-N34X/DC...V	R3-N38X/DC...V
LED + free wheeling diode	R3-N34DX/DC...V	R3-N38DX/DC...V*

"..." Enter the voltage for full type designation

Accessories

Socket:	C11A, C12B0
Optional accessories (blanking plug):	SO-NP, SO-OP

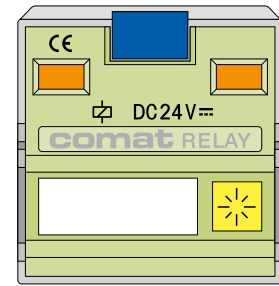

Connection diagram

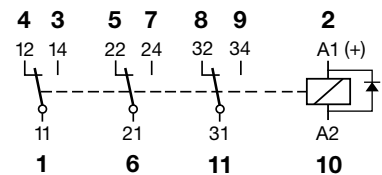

Fig. 1 AC voltage endurance

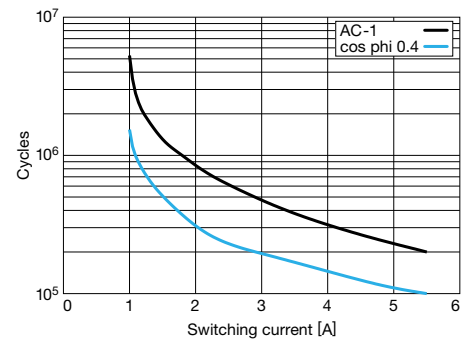
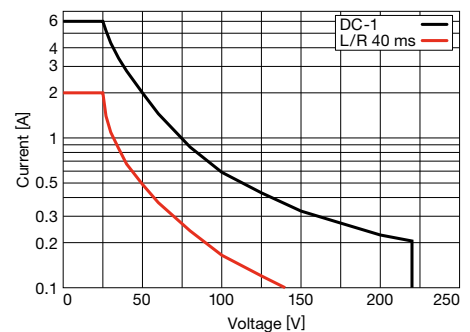
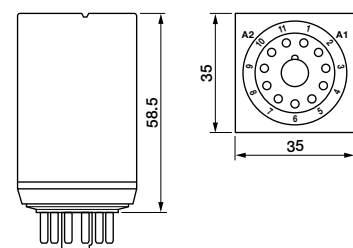

Fig. 2 DC load limit curve



Dimensions [mm]



Technical approvals, conformities

See table on page 53.

R4-A4...

14-pin plug-in relay, 4-pole, change-over contacts

Type: R4-A4xx/...V

Relays for Railway application, 4 change-over contacts

Maximum contact load	6 A / 250 V AC-1, 0.5 A / 110 V DC-1 6 A / 30 V DC-1, 0.2 A / 220 V DC-1
Recommended minimum contact load	10 mA / 10 V Code 4 5 mA / 5 V Code 8

Contacts

Material	Optional	Code 4	AgNi + 0,2 μ Au
	Optional	Code 8	AgNi + 10 μ Au
Rated current			6 A
Inrush current max. (20 ms)			18 A
Switching voltage AC-1 max.			250 V
AC load max.			see Fig.1
DC load max.			see Fig. 2

Coil (Values are valid at 20 °C)

Coil resistance	see table; tolerance ± 10 %
Operating voltage range	0.7 ... 1.25 U _N
Nominal power	1.4 W

Coil Table

V DC	Ω	mA
24	426	56
36	881	41
48	1500	32
72	3456	21
110	8231	13

Insulation

Pulse (1.2 / 50 us / Dielectric strength (V rms, 1 minute)	
Contact / coil	4 kV / 2.5 kV
Contact / contact	4 kV / 2.5 kV
Contact open	1.5 kV / 1 kV

Specifications

Ambient temperature operation / storage	-25 (no ice) ... +55 °C / -40 ... +80 °C
Pick-up time / bounce time	15 ms / ≤ 2 ms
Release time / bounce time	20 ms / ≤ 2 ms
Mechanical life	> 20 millions
Ingress protection rating	IP40
Weight	90 g

Standard types

DC: 24, 36, 48, 72, 110 V

LED

Free wheeling diode

Polarity and free wheeling diode

R4-A44/DC...V

R4-A44X/DC...V

R4-A44DX/DC...V

R4-A44FX/DC...V

R4-A48/DC...V

R4-A48X/DC...V

R4-A48DX/DC...V

R4-A48FX/DC...V

"..." Enter the voltage for full type designation

Accessories

Socket:	CS-144
Optional accessories (blanking plug):	SO-NP, SO-OP

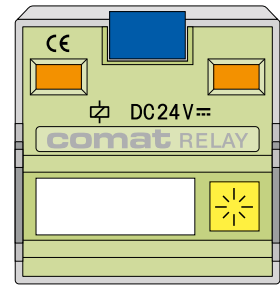

Connection diagram

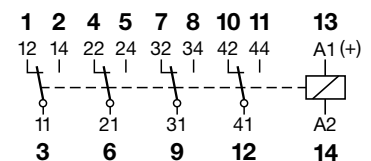

Fig. 1 AC voltage endurance

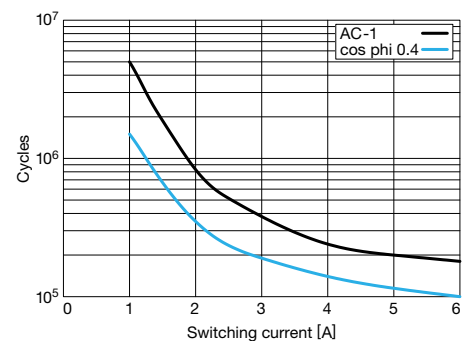
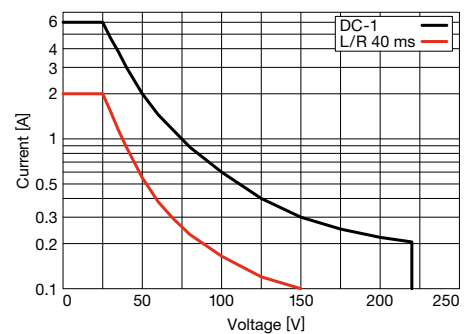
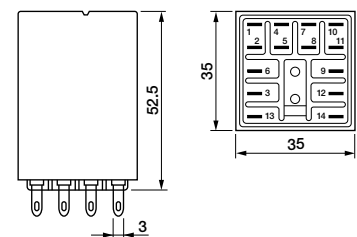

Fig. 2 DC load limit curve



Dimensions [mm]



Technical approvals, conformities

See table on page 53.

R7-A2...

8-pin plug-in miniature relay, 2-pole, change-over contacts



Type: R7-A2x/...V

Relays for Railway application, sensitive, 2 change-over contacts

Maximum contact load:	10 A / 250 V AC-1, 10 A / 30 V DC-1
Recommended minimum contact load	10 mA / 10 V Code 4 5 mA / 5 V Code 8

Contacts

Material	Optional	Code 4	AgNi + 0.2μ Au
	Optional	Code 8	AgNi + 10μ Au
Rated current			10 A
Inrush current max. (20 ms)			30 A
Switching voltage AC-1 max.			250 V
AC load max.			see Fig. 1
DC load max.			see Fig. 2

Coil (Values are valid at 20 °C)

Coil resistance	see table; tolerance ±10 %
Operating voltage range	0.7 ... 1.25 U _N
Nominal power	1.1 W

Coil Table

V DC	Ω ±10%	mA
24	535	45
48	2004	24
72	4750	15
110	11337	10

Insulation

Pulse (1.2 / 50 us / Dielectric strength (V rms, 1 minute)	
Contact / coil	4 kV / 2.5 kV
Contact / contact	4 kV / 2.5 kV
Contact open	1.5 kV / 1 kV

Specifications

Ambient temperature operation / storage	-25 (no ice) ... +70 °C / -40 ... +80 °C
Number of mechanical operations	> 20 millions
Pick-up time typ.	10 ms
Release time typ.	15 ms
Ingress protection rating	IP40
Weight	35 g

Standard types

DC: 24, 48, 72, 110 V

LED:

Free wheeling diode:

LED + free wheeling diode:

R7-A24/DC...V	R7-A28/DC...V
R7-A24X/DC...V	R7-A28X/DC...V
R7-A24D/DC...V	R7-A28D/DC...V
R7-A24DX/DC...V	R7-A28DX/DC...V

"..." Enter the voltage for full type designation

Accessories

Socket: **CS-118**

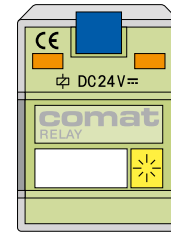

Connection diagram

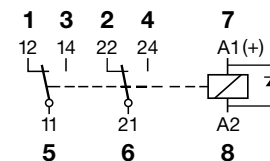

Fig. 1 AC voltage endurance

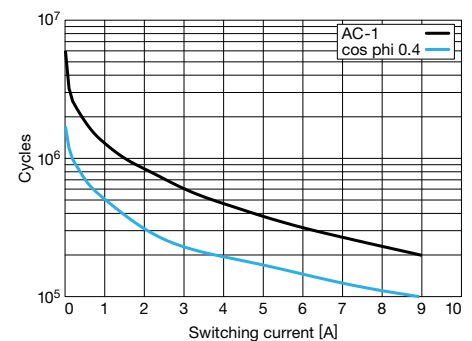
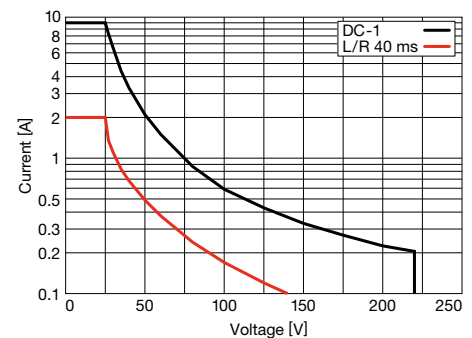
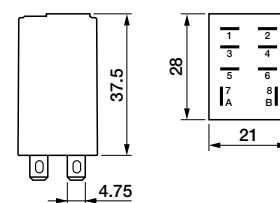

Fig. 2 DC load limit curve



Dimensions [mm]



Technical approvals, conformities

See table on page 53.

R7-T2...

8-pin plug-in miniature relay, 2-pole, change-over twin contacts

Type: R7-T2x/...V

Relays for Railway application, 2 change-over twin contacts

Maximum contact load	6 A / 250 V AC-1, 6 A / 30 V DC-1
Recommended minimum contact load	5 mA / 5 V Code 1 1 mA / 5 V Code 2

Contacts

Material	Standard	Code 1	AgNi + 0.2μ Au
	Optional	Code 2	AgNi + 10μ Au
Rated current	6 A		
Inrush current max. (20 ms)	15 A		
Switching voltage AC-1 max.	250 V		
AC load max.	see Fig. 1		
DC load max.	see Fig. 2		

Coil (Values are valid at 20 °C)

Coil resistance	see table; tolerance ± 10 %
Operating voltage range	0.7 ... 1.25 U _N
Nominal power	1.1 W

Coil Table

V DC	Ω ±10%	mA
24	535	45
48	2004	24
72	4750	15
110	11337	10

Insulation

Pulse (1.2 / 50 us / Dielectric strength (V rms, 1 minute)	
Contact / coil	4 kV / 2.5 kV
Contact / contact	4 kV / 2.5 kV
Contact open	1.5 kV / 1 kV

Specifications

Ambient temperature operation / storage	-25 (no ice) ... +70 °C / -40 ... +80 °C
Number of mechanical operations	> 20 millions
Pick-up time typ.	10 ms
Release time typ.	15 ms
Ingress protection rating	IP40
Weight	35 g

Standard types

DC: 24, 48, 72, 110 V

LED:

Free wheeling diode:

LED + free wheeling diode:

R7-T21/DC...V	R7-T22/DC...V
R7-T21X/DC...V	R7-T22X/DC...V
R7-T21D/DC...V	R7-T22D/DC...V
R7-T21DX/DC...V	R7-T22DX/DC...V

"..." Enter the voltage for full type designation

Accessories

Socket: **CS-118**

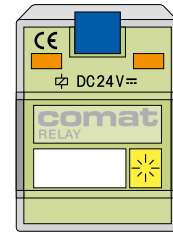

Connection diagram

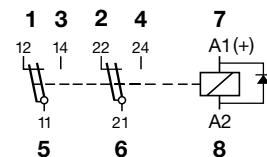

Fig. 1 AC voltage endurance

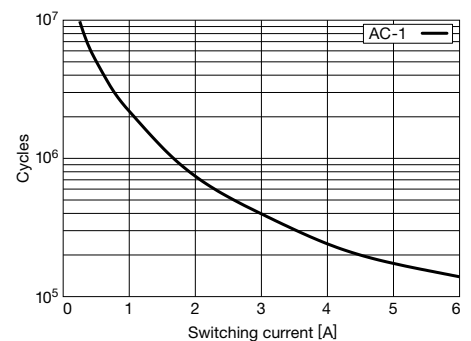
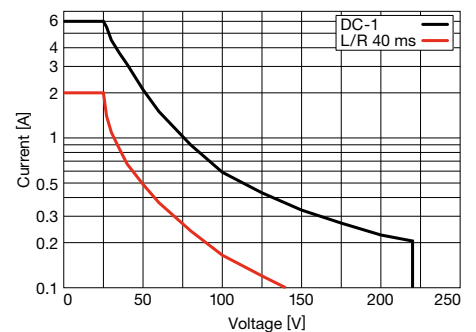
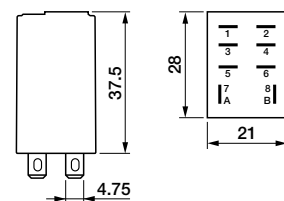

Fig. 2 DC load limit curve



Dimensions [mm]



Technical approvals, conformities

See table on page 53.

CINT-21

Interface module with mechanical change-over output contact, DIN rail mounting

Types: CINT-21/...V

Standard interface module, 1 change-over contact

Cage clamp terminal

Control voltage UC 24 V, 50/60 Hz

Green LED for status indication

Max. contact load **6 A / 250 V AC-1**

Contact Data

Type	micro disconnection
Material	AgSnO ₂
Rated current	6 A
Inrush current max. (5 ms)	30 A
Switching voltage AC-1 max.	250 V
AC load max.	1500 VA
DC load max.	see Fig. 2
Recommended min. contact load	10 mA / 12 V

Control input V_n = UC 24 V

Operating voltage range	16.3 ... 30 V
Typical input current	11 mA
Nominal power consumption	260 mW

Insulation

Pulse (1.2 / 50 us / Dielectric strength (V rms, 1 minute)

Contact / coil	6 kV / 4 kV
Contact open	1.5 kV / 1 kV

General Specifications

Ambient temperature operation / storage	-40 ... +70 °C / -40 ... +85 °C
Typical response time @ V _n	5 ms
Typical release time @ V _n	10 ms
Service life mech. / elec.	≥ 10 ⁷ / ≥ 10 ⁵ operations
Cond. cross section cage clamp terminal	stranded wire 0.5 ... 1.5 mm ²
Ingress protection rating	IP 20
Mounting position	any
Housing material	Polyamid

Standard types

UC 24 (AC/DC): **CINT-21/UC24V**

Accessories

Plug-in bridges:

Label plate:

Replacement relay for CINT-21:

CINT-BR20 (2 x 10 pin)
CINT-BEZ/64 (64 pieces)
CINT-R1/DC24V

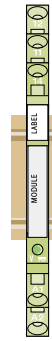

Connection diagram

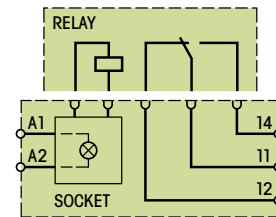

Fig. 1 AC voltage endurance

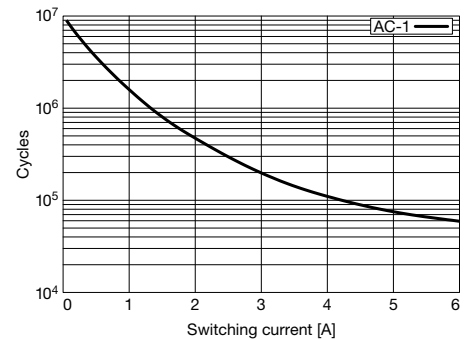
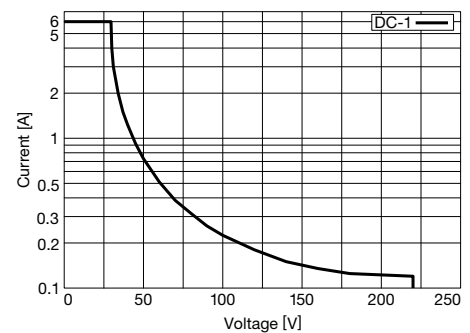
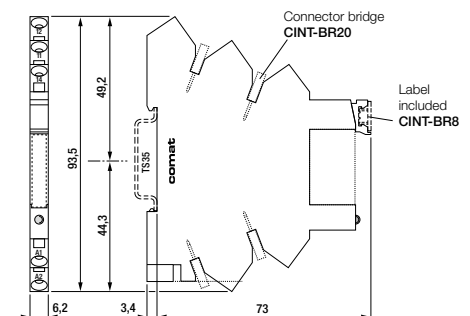

Fig. 2 DC load limit curve



Dimensions [mm]



Technical approvals, conformities

See table on page 53.

CINT-22**Interface module with mechanical change-over output contact, DIN rail mounting****Types: CINT-22/UC24V**

Standard interface module, 1 change-over contact

Cage clamp terminal

Control voltage UC 24 V, 50/60 Hz

Green LED for status indication

Max. contact load **6 A / 250 V AC-1****Contact Data**

Type	micro disconnection
Material	AgNi +5μAu
Rated current	6 A
Inrush current max. (20 ms)	10 A
Switching voltage AC-1 max.	250 V
AC load max.	1500 VA
DC load max.	see Fig. 2
Recommended min. contact load	1 mA / 1 V

Control input $V_n =$ **UC 24 V**

Operating voltage range	16.8 ... 30 V
Typical input current	11 mA
Nominal power consumption	260 mW

Insulation

Pulse (1.2 / 50 us / Dielectric strength (V rms, 1 minute)

Contact / coil	6 kV / 4 kV
Contact open	1.5 kV / 1 kV

General Specifications

Ambient temperature operation / storage	-40 ... +70 °C / -40 ... +85 °C
Typical response time @ V_n	5 ms
Typical release time @ V_n	10 ms
Service life mech. / elec.	$\geq 10^7$ / $\geq 10^5$ operations
Cond. cross section cage clamp terminal	stranded wire 0.5 ... 1.5 mm ²
Ingress protection rating	IP 20
Mounting position	any
Housing material	Polyamid

Standard types**UC 24 (AC/DC):** **CINT-22/UC24V****Accessories**

Plug-in bridges:

Label plate:

Replacement relay for CINT-22:

CINT-BR20 (2 x 10 pin)
CINT-BEZ/64 (64 pieces)
CINT-R2/DC24V

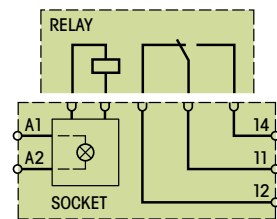
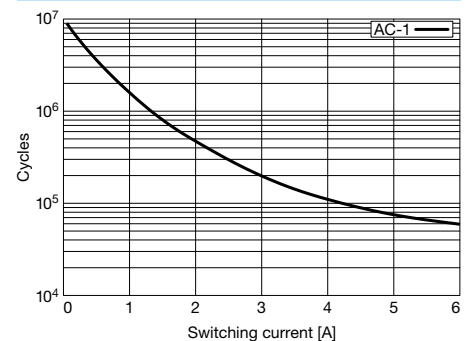
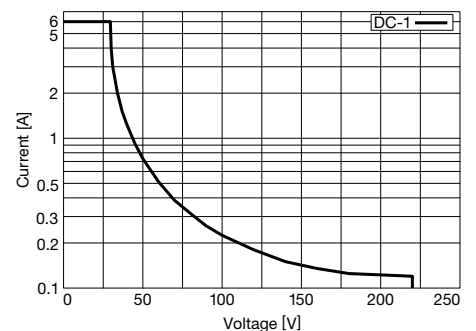
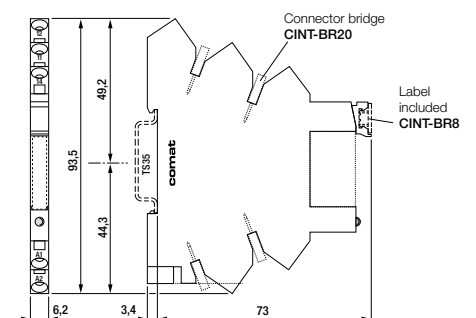
**Connection diagram****Fig. 1 AC voltage endurance****Fig. 2 DC load limit curve****Dimensions [mm]****Technical approvals, conformities**

See table on page 53.

CINT-25

Interface module with solide state DC output, DIN rail mounting

Types: CINT-25/UC24V

Standard interface module, Solide state DC

Cage clamp terminal

Control voltage UC 24 V, 50/60 Hz

Green LED for status indication

Max. contact load **2 A / 24 V DC-1**

Contact Data

Type	micro disconnection
Material	Solide state
Rated current	2 A
Inrush current max. (10 ms)	20 A
Switching voltage DC-1 max.	30 V
DC load max.	48 W
Recommended min. contact load	1 mA, 6 V

Control input V_n = UC 24 V

Operating voltage range	16.8 ... 30 V
Typical input current	11 mA
Nominal power consumption	260 mW

Insulation

Pulse (1.2 / 50 us / Dielectric strength (V rms, 1 minute)

Input / output - / 2.5 kV

General Specifications

Ambient temperature operation / storage	-40 ... +55 °C / -40 ... +85 °C
Typical response time @ V _n	1 ms
Typical release time @ V _n	1 ms
Cond. cross section cage clamp terminal	stranded wire 0.5 ... 1.5 mm ²
Ingress protection rating	IP 20
Mounting position	any
Housing material	Polyamid

Standard types

UC 24 (AC/DC): **CINT-25/UC24V**

Accessories

Plug-in bridges:	CINT-BR20 (2 x 10 pin)
Label plate:	CINT-BEZ/64 (64 pieces)
Replacement relay for CINT-25:	CINT-R5/DC24V

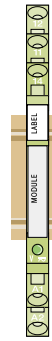

Connection diagram

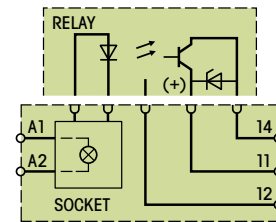

Dimensions [mm]

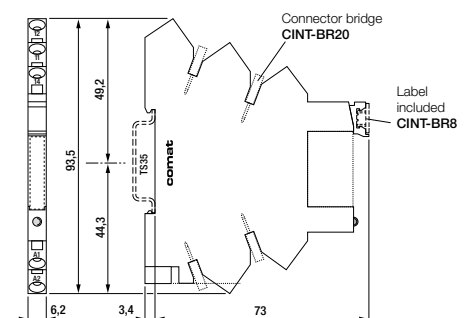

Technical approvals, conformities

See table on page 53.

CINT-61

Interface module with mechanical change-over output contact, DIN rail mounting

Types: CINT-61/UC24V

Standard interface module, 1 change-over contact

Cage clamp terminal

Control voltage UC 24 V, 50/60 Hz

Green LED for status indication

Max. contact load **10 A / 250 V AC-1**

Contact Data

Type	micro disconnection
Material	AgSnO ₂
Rated current	10 A / (16 A*)
Inrush current max. (5 ms)	80 A
Switching voltage AC-1 max.	250 V
AC load max.	4000 VA
DC load max.	see Fig. 2
Recommended min. contact load	10 mA, 24 V

* For currents > 10 A, contact terminals must be connected in parallel (21 with 11, 24 with 14, 22 with 12)

Control input V_n = UC 24 V

Operating voltage range	16.8 ... 30 V
Typical input current	20 mA
Nominal power consumption	480 mW

Insulation

Pulse (1.2 / 50 us / Dielectric strength (V rms, 1 minute)

Contact / coil	6 kV / 4 kV
Contact open	1.5 kV / 1 kV

General Specifications

Ambient temperature operation / storage	-40 ... +70 °C / -40 ... +85 °C
Typical response time @ V _n	5 ms
Typical release time @ V _n	10 ms
Service life mech. / elec.	≥ 10 ⁷ / ≥ 10 ⁵ operations
Cond. cross section cage clamp terminal	stranded wire 0.5 ... 1.5 mm ²
Ingress protection rating	IP 20
Mounting position	any
Housing material	Polyamid

Standard types

UC 24 (AC/DC): **CINT-61/UC24V**

Accessories

Plug-in bridges:	CINT-BR8/5 (5 pieces x 8 pin)
Label plate:	CINT5-BEZ/18 (18 pieces)
Replacement relay for CINT-61:	CINT-R21/DC24V

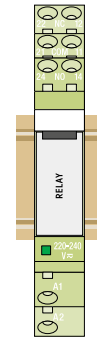

Connection diagram

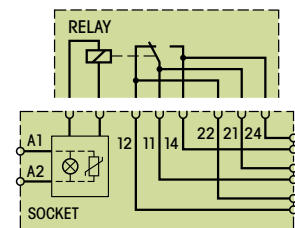

Fig. 1 AC voltage endurance

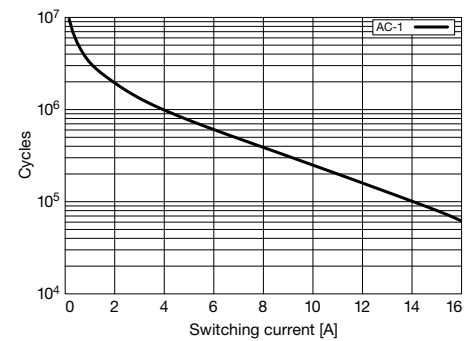
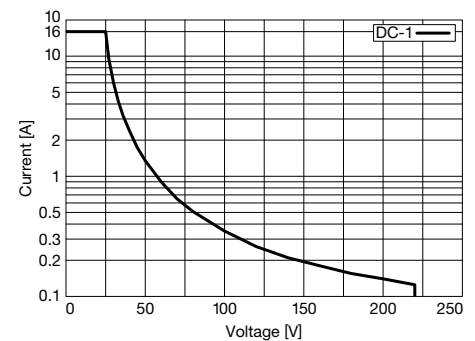
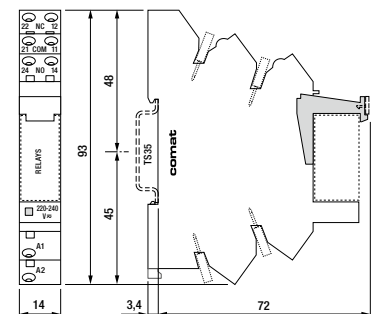

Fig. 2 DC load limit curve



Dimensions [mm]



Technical approvals, conformities

See table on page 53.

CINT-62

Interface module with 2 mechanical change-over output contacts, DIN rail mounting

Types: CINT-62/UC24V

Standard interface module, 1 change-over contact

Cage clamp terminal

Control voltage UC 24 V, 50/60 Hz

Green LED for status indication

Max. contact load **8 A / 250 V AC-1**

Contact Data

Type	micro disconnection
Material	AgNi + 5µAu
Rated current	8 A
Inrush current max. (20 ms)	15 A
Switching voltage AC-1 max.	250 V
AC load max.	2000 VA
DC load max.	see Fig. 2
Recommended min. contact load	5 mA / 5 V

Control input V_n = UC 24 V

Operating voltage range	16.8 ... 30 V
Typical input current	20 mA
Nominal power consumption	480 mW

Insulation

Pulse (1.2 / 50 us / Dielectric strength (V rms, 1 minute)	
Contact / coil	6 kV / 4 kV
Contact / contact	4 kV / 2 kV
Contact open	1.5 kV / 1 kV

General Specifications

Ambient temperature operation / storage	-40 ... +70 °C / -40 ... +85 °C
Typical response time @ V _n	5 ms
Typical release time @ V _n	10 ms
Service life mech. / elec.	≥ 10 ⁷ / ≥ 10 ⁵ operations
Cond. cross section spring cage	stranded wire 0.5 ... 1.5 mm ²
Ingress protection rating	IP 20
Mounting position	any
Housing material	Polyamid

Standard types

UC 24 (AC/DC): **CINT-62/UC24V**

Accessories

Plug-in bridges:	CINT-BR8/5 (5 pieces x 8 pin)
Label plate:	CINT5-BEZ/18 (18 pieces)
Replacement relay for CINT-62:	CINT-R22/DC24V

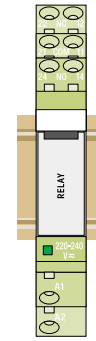

Connection diagram

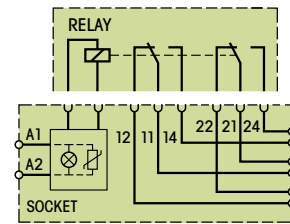

Fig. 1 AC voltage endurance

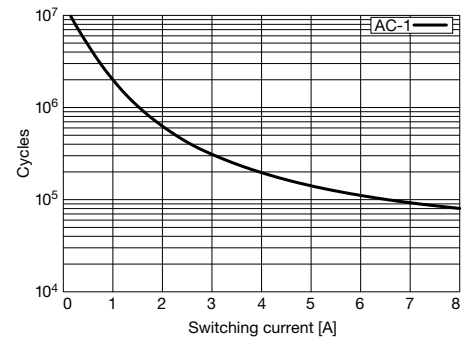
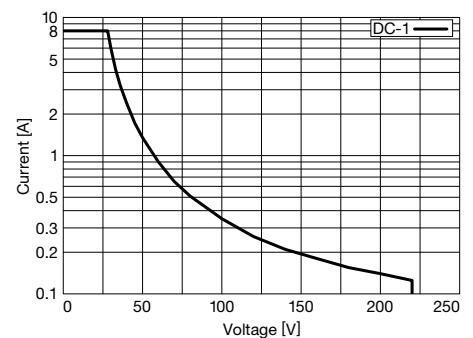
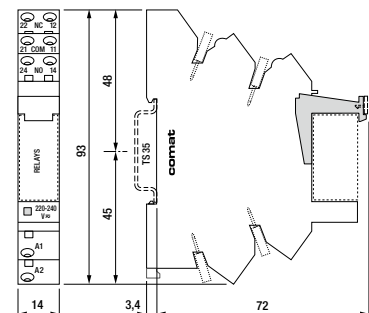

Fig. 2 DC load limit curve



Dimensions [mm]



Technical approvals, conformities

See table on page 53.

CINT-63

Interface module with 2 mechanical change-over output contacts, DIN rail mounting

Types: CINT-63/UC24V

Standard interface module, 1 change-over contact

Cage clamp terminal

Control voltage UC 24 V, 50/60 Hz

Green LED for status indication

Max. contact load **8 A / 250 V AC-1**

Contact Data

Type	micro disconnection
Material	AgNi
Rated current	8 A
Inrush current max. (20 ms)	15 A
Switching voltage AC-1 max.	250 V
AC load max.	2000 VA
DC load max.	see Fig. 2
Recommended min. contact load	10 mA / 24 V

Control input $V_n =$ **UC 24 V**

Operating voltage range	16.8 ... 30 V
Typical input current	20 mA
Nominal power consumption	480 mW

Insulation

Pulse (1.2 / 50 us / Dielectric strength (V rms, 1 minute)	
Contact / coil	6 kV / 4 kV
Contact / contact	4 kV / 2 kV
Contact open	1.5 kV / 1 kV

General Specifications

Ambient temperature operation / storage	-40 ... +70 °C / -40 ... +85 °C
Typical response time @ V_n	5 ms
Typical release time @ V_n	10 ms
Service life mech. / elec.	$\geq 10^7 / \geq 10^5$ operations
Cond. cross section cage clamp terminal	stranded wire 0.5 ... 1.5 mm ²
Ingress protection rating	IP 20
Mounting position	any
Housing material	Polyamid

Standard types

UC 24 (AC/DC): **CINT-63/UC24V**

Accessories

Plug-in bridges:	CINT-BR8/5 (5 pieces x 8 pin)
Label plate:	CINT5-BEZ/18 (18 pieces)
Replacement relay for CINT-63:	CINT-R23/DC24V

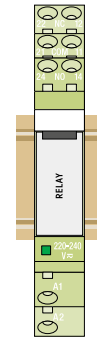

Connection diagram

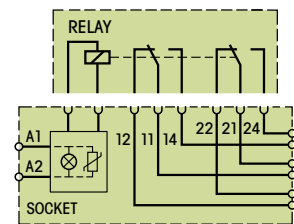

Fig. 1 AC voltage endurance

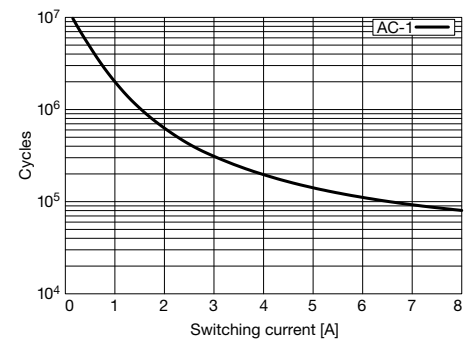
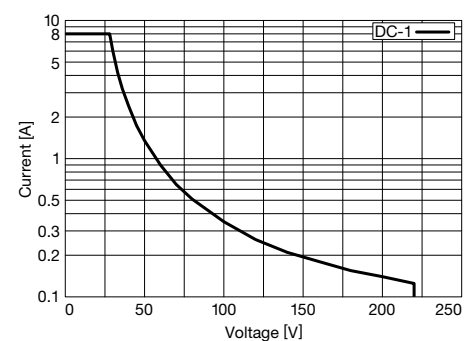
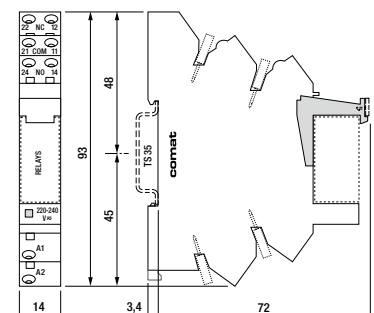

Fig. 2 DC load limit curve



Dimensions [mm]



Technical approvals, conformities

See table on page 53.

C203.06R

Interface module with 2 mechanical change-over twin contacts, DIN rail mounting

Types: 203.06R/...V

Standard interface module, 2 separate change-over contacts
 Screw terminals
 Control voltage UC 24 or 36 V, 50/60 Hz
 LED status indicator for each channel
 Sealed relays built in
 Also suitable for panel mounting 2 x M4

Max. contact load **2 A / 30 V DC-1**

Contact Data

Type	twin contacts
Material	Ag +Au
Rated current	2 A
Switching voltage AC-1 max.	125 V
AC load max.	100 VA
DC load max.	see Fig. 2
Recommended min. contact load	10 µA / 10 mV

Control input $V_n =$	UC 24 V	UC 36 V
Operating voltage range	16.8 ... 30 V	25.2 ... 45 V
Typical input current	18 mA	9 mA
Nominal power consumption (per channel)	220 mW	330 mW

Insulation

Contact / Coil 2.5 kVrms 1 minute

General Specifications

Ambient temperature operation / storage	-40 ... +70 °C / -40 ... +85 °C
Typical response time @ V_n	10 ms
Typical release time @ V_n	20 ms
Service life mech. / elec.	$\geq 10^7$ / $\geq 10^5$ operations
Cond. cross section screw terminal	stranded wire 2.5 mm ² , 2 x 1.5 mm ²
Ingress protection rating	IP 20
Max. screw torque	0.4 Nm
Mounting position	any
Housing material	Lexan
Weight	80 g

Standard types

UC (AC DC): 24, 36 V **C203.06R/UC...V**

"..." Enter the voltage for full type designation

Accessories

Label plate: **BZS-DIN17.5**



Connection diagram

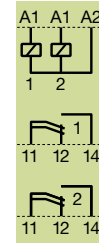

Fig. 1 DC voltage endurance

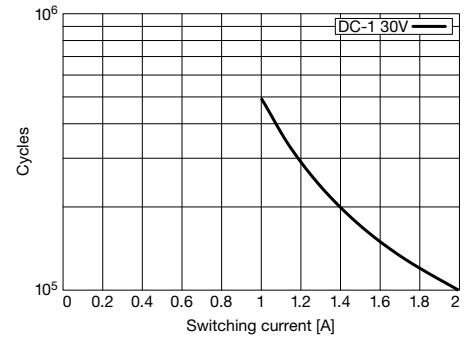
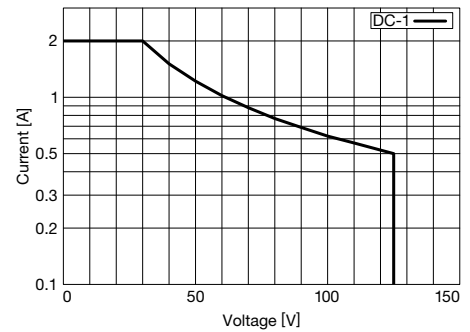
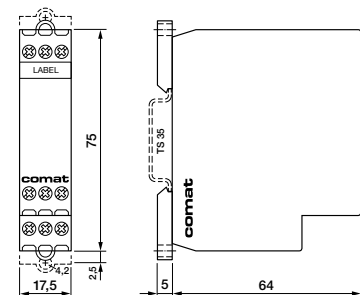

Fig. 2 DC load limit curve



Dimensions [mm]



Technical approvals, conformities

See table on page 53.

Power relays

RIC20-...
**20 A, AC/DC control voltage, silent operation,
DIN rail mounting according to DIN 43 880**
Type: RIC20-xxx/...V

Hum-free installation contactor, 2 contacts, 2 NO, 1 NO-1 NC, 2 NC types available

Rated operational power **4 kW / 230 V AC-1, 0.5 A / 220 V DC-1**
Recommended minimum contact load **10 mA / 24 V**
Contacts

Material	AgNi
Rated current	20 A
Inrush current max. (100 ms)	50 A
Switching voltage AC-1 max.	400 V
AC load max. AC-1, AC-7a	4 kW / 230 V
AC-3	1.3 kW /230 V (NO contact only)
DC load max.	see Fig. 1

Control input $V_n =$

	UC 24 V	UC 36 V	UC 230 V
Operating voltage range [V]	20.4 ... 26.4	30.6 ... 39.6	195 ... 253
Typ. pick up voltage [V]	17	25	160
Typ. release voltage [V]	7	11	70
Power consumption [W]	≤ 2.5	≤ 2.5	≤ 2.5
Inductive turn-off voltage	None	None	None
Surge immunity EN 61000-4-5	2 kV	2 kV	2 kV

Insulation

Rated insulation voltage	230 V
Rated impulse withstand voltage	4 kV
Min. clearance of open contact	3.6 mm

General Specifications

Ambient temperature storage	-30 ... +80 °C
operation, Spacer after 2 contactors side by side	-5 ... +55 °C
operation, Spacer after 3 contactors side by side	-5 ... +40 °C
Pick-up time	15 ... 45 ms
Release time	20 ... 50 ms
Mechanical life	≥ 3 x 10 ⁶ operations
AC voltage endurance at rated load AC-3, AC-7b	≥ 3 x 10 ⁵ operations
DC voltage endurance at rated load DC-1	10 ⁵ operations
Operating frequency at rated load DC-1	≤ 300 operations / h
Operating frequency at rated load AC-1	≤ 600 operations / h
Conductor cross section coil /contacts	Stranded wire 2.5 mm ² / 6 mm ²
Max. Screw torque coil / contacts	0.6 Nm / 1.2 Nm
Ingress protection rating	IP 20
Weight	140 g

Standard types

UC (AC/DC) 50/60 Hz: 24, 36, 230 V	2NO: RIC20-200/UC ...V
	1NO + 1NC: RIC20-110/UC ...V
"..." Enter the voltage for full type designation	2NC: RIC20-020/UC ...V

Accessories

Auxiliary contact bloc:	RIC-AUX... RIC25, 40, 63
Sealing cover:	RIC-SEAL20
Spacer:	RIC-DIST

Samples of lamp loads

	Number of lamps
Incandescent lamps 230 V / 100 W	20
Fluorescent lamps not corrected 230 V / 36 W	17
Fluorescent lamps electronic ballast units 36 W	15

Mounting information

If multiple contactors are mounted side by side, spacers (RIC DIST) have to be inserted for the purpose of heat dissipation.

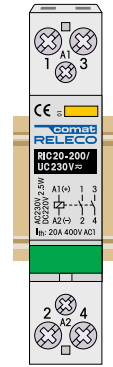
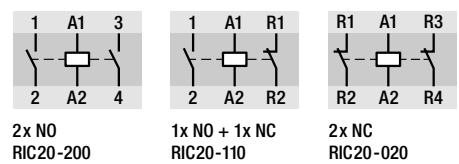
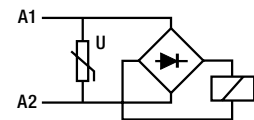
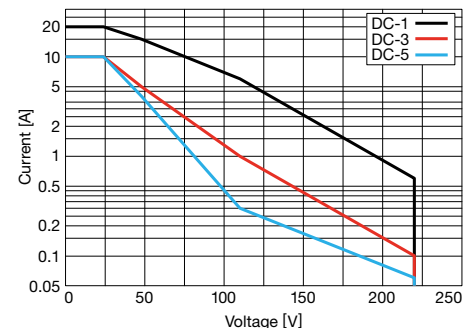
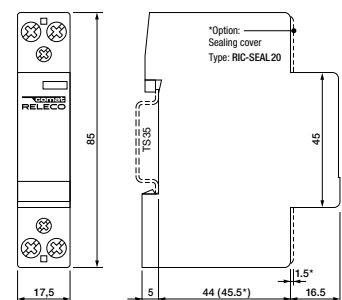
Example: Ambient temperature up to 40°C: 1 spacer after 3 RIC // 40...55°C: 1 spacer after 2 RIC.

Connection diagram

Coil circuit

Fig. 1 DC load limit curve DC-1

Dimensions [mm]

Technical approvals, conformities

See table on page 53.

RIC25-...

**25 A, AC/DC control voltage, silent operation
DIN Rail mounting according to DIN 43 880**



Type: RIC25-xxx/...V

Hum-free installation contactor, 4 contacts, 4 NO, 4 NC, 2 NO-2 NC types available

Rated operational power AC-1	Single phase: 5.4 kW/230 V, 0.5 A/220 V DC-1
	3 phase 230 V: 9 kW
	3 phase 400 V: 16 kW

Recommended minimum contact load	10 mA / 24 V
	see Fig. 1

Contacts

Material	AgNi
Rated current	25 A
Inrush current max. (100 ms)	50 A
Switching voltage AC-1 max.	400 V
AC load max. AC-1, AC-7a	4 kW / 230 V
AC-3	2.2 kW /230 V, 4 kW / 400 V
DC load max.	see Fig. 1

Control input V_n =

	UC 24 V	UC 36 V	UC 230 V
Operating voltage range [V]	20.4 ... 26.4	30.6 ... 39.6	195 ... 253
Typ. pick up voltage [V]	17	25	160
Typ. release voltage [V]	7	11	70
Power consumption [W]	≤ 3	≤ 3	≤ 3
Inductive turn-off voltage	None	None	None
Surge immunity EN 61000-4-5	2 kV	2 kV	2 kV

Insulation

Rated insulation voltage	440 V
Rated impulse withstand voltage	4 kV
Min. clearance of open contact	3.6 mm

General Specifications

Ambient temperature storage	-30 ... +80 °C
operation, Spacer after 2 contactors side by side	-5 ... +55 °C
operation, Spacer after 3 contactors side by side	-5 ... +40 °C
Pick-up time	15 ... 45 ms
Release time	20 ... 70 ms
Mechanical life	≥ 3 x 10 ⁶ operations
AC voltage endurance at rated load AC-3, AC-7b	≥ 5 x 10 ⁵ operations
DC voltage endurance at rated load DC-1	10 ⁵ operations
Operating frequency at rated load DC-1	≤ 300 operations / h
Operating frequency at rated load AC-1, AC-3	≤ 600 operations / h
Conductor cross section coil / contacts terminals	Stranded wire 2.5 mm ² / 6 mm ²
Max. Screw torque coil / contacts	0.6 Nm / 1.2 Nm
Ingress protection rating	IP 20
Weight	270 g

Standard types

UC (AC/DC) 50/60 Hz: 24, 36, 230 V	4NO: RIC25-400/UC...V
	2NO + 2NC: RIC25-220/UC...V
	4NC: RIC25-040/UC...V

"..." Enter the voltage for full type designation

Accessories

Auxiliary contact bloc:	RIC-AUX...
Sealing cover:	RIC-SEAL25
Spacer:	RIC-DIST

Samples of lamp loads

	Number of lamps
Incandescent lamps 230 V/ 100 W	20
Fluorescent lamps not corrected 230 V/ 36 W	20
Fluorescent lamps electronic ballast units 36 W	20

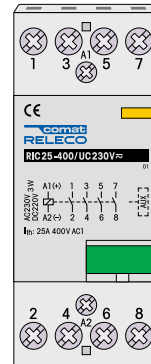

Connection diagram

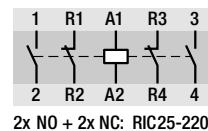
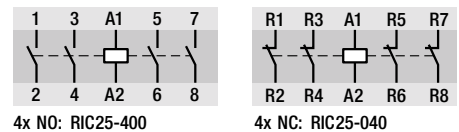

Coil circuit

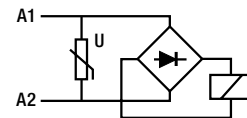
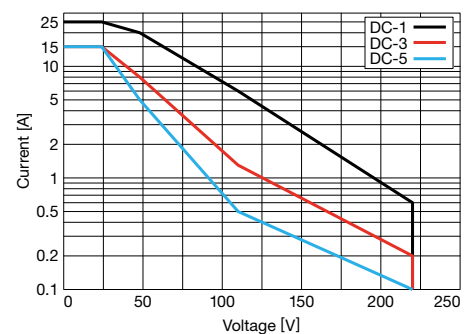
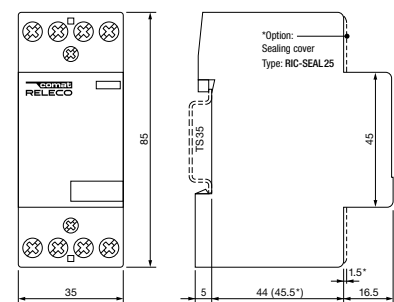

Fig. 1 DC load limit curve DC-1



Dimensions [mm]



Technical approvals, conformities

See table on page 53.

Mounting information
If multiple contactors are mounted side by side, spacers (RIC DIST) have to be inserted for the purpose of heat dissipation.
Example: Ambient temperature up to 40°C: 1 spacer after 3 RIC // 40...55°C: 1 spacer after 2 RIC.

2. Time Relays

◉ TF-60 Setting of long times

The TF60 time setting method permits short examination of long delay time settings. Elapsing times of hours can be monitored in the sec. range.

Example for a delay time of 38h:

1. Set range switch to 60sec
 2. Set 38sec on the potentiometer (e.g. check 38sec by chronometer)
 3. Set range switch to 60h
- The delay time now amounts to 38h.

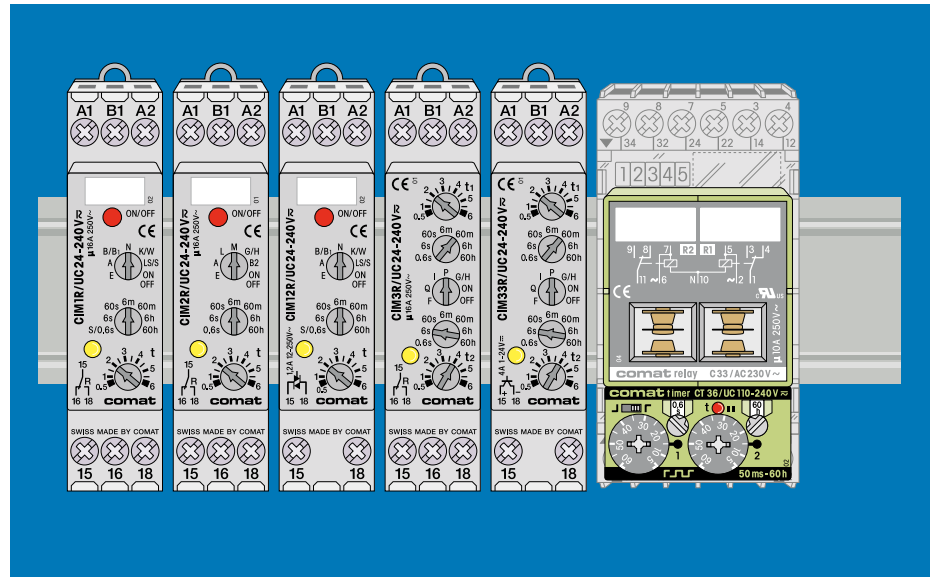

Application	Types	Functions*	t min. – max.	Output contacts	Design
Time relay with mechanical CO output contact	CIM1R	E, A, W, N, K, B, B1, S, LS	50 ms – 60 h [◊]	16 A 250 V	
Time relay with AC solide-state output	CIM12R	E, A, W, N, K, B, B1, S, LS	50 ms – 60 h [◊]	2 A 250 V	
Time relay with DC solide-state output	CIM13R	E, A, W, N, K, B, B1, S, LS	50 ms – 60 h [◊]	5 A 24 V ⁼⁼	
Time relay with mechanical CO output contact	CIM2R	E, A, L, M, B2, G, H	50 ms – 60 h [◊]	16 A 250 V	
Time relay with AC solide-state output	CIM22R	E, A, L, M, B2, G, H	50 ms – 60 h [◊]	2 A 250 V	
Time relay with AC solide-state output	CIM23R	E, A, L, M, B2, G, H	50 ms – 60 h [◊]	5 A 24 V ⁼⁼	
Time relay with mechanical CO output contact	CIM3R	F, Q, G, H, I, P	50 ms – 60 h [◊]	16 A 250 V	
Time relay with AC solide-state output	CIM32R	F, Q, G, H, I, P	50 ms – 60 h [◊]	2 A 250 V	
Time relay with DC solide-state output	CIM33R	F, Q, G, H, I, P	50 ms – 60 h [◊]	5 A 24 V ⁼⁼	
Modular time relay with power CO output contacts	CT32.31	E, A, W, N, K, B, B1	0.15 s – 60 min	10 A	
Modular time relay with 3 twin CO output contacts	CT32.32	E, A, W, N, K, B, B1	0.15 s – 60 min	6 A	
Modular time relay with power CO output contacts	CT33.31	E, A, F, W, N, Q, K, L, B, B1, G, H	30 ms – 60 h [◊]	10 A	
Modular time relay with 3 twin CO output contacts	CT33.32	E, A, F, W, N, Q, K, L, B, B1, G, H	30 ms – 60 h [◊]	6 A	
Modular time relay with power CO output contacts	CT36.31	I, P	2x 50 ms – 60 h [◊]	10 A	
Modular time relay with 3 twin CO output contacts	CT36.32	I, P	2x 50 ms – 60 h [◊]	6 A	

*Function diagrams: refer to page 20

Delay functions

E On delay

 S ⇒ R on with delay
 S OFF ⇒ R off

A Off delay

 S ⇒ R on
 S OFF ⇒ R off with delay

F On and off delay

 S ⇒ R on with delay (t1)
 S OFF ⇒ R off with delay (t2)

Shot timing modes

W One shot leading edge

 S ⇒ R on for t
 S OFF ⇒ R off
 (pulse clipping)

N One shot trailing edge

 S OFF ⇒ R on for t
 S on for t ⇒ R off

Q One shot leading and trailing edge

 S ⇒ R on for t1
 S OFF ⇒ R on for t2
 S OFF off for t1 ⇒ R off

Puls shaping

K Puls shaping

 S (pulse or continuous contact) ⇒ R on for t
 S... no influence on R and t

L Pulse shaping, retrigger (subsequ.time operation from 0)

 S (pulse or continuous contact) ⇒ R on for t
 S on for t = tRESET

M Puls shaping

 S OFF ⇒ R on for t
 S... no influence on R and t

Blinker functions

B Blinker, pulse start

 S ⇒ R on/off periodically according to t
 S OFF ⇒ R off

B1 Blinker, pulse start, trailing pulse

 S ⇒ R on/off periodically according to t
 S OFF: last pulse = t

B2 Blinker, interval start

 S ⇒ R after t on/off periodically according to t
 S OFF ⇒ R off

Delayed pulse

G On delay single shot

 S (pulse or continuous contact) ⇒ R after t1 on for t2
 S... no influence on R and t

H On delay single shot

 S ⇒ R after t1 on for t2
 S OFF ⇒ R off

Repeat cycle timer

I Repeat cycle timer, pulse start

 S ⇒ R on/off periodically according to t1 and t2
 S OFF ⇒ R off

P Repeat cycle timer, interval start **C55, CT1: t2 t1**

 S ⇒ R after t1 (t2) on/off periodically according to t2 and t1
 S OFF ⇒ R off

Special functions

Y Star-delta timer

 S ⇒ R on for t
 R OFF ⇒ Δ on with delay for t Δ
 S OFF ⇒ Δ off

X1 Restart delay

 S ⇒ R on
 S OFF ⇒ R off and starts t
 S ⇒ R restart only after t

Special functions

S Step-on / Step-off switch

 S ⇒ R on/off

LS Step-switching (staircase lighting timer), with time lapse

 S ⇒ R on and starts t
 S on for t ⇒ R off

Stop / Reset

tSTOP SSTOP interrupts t (t-addition) **T** t is stopped ⇒ R on/off

tRESET SRESET reset t t restarts immediately **T** Test

S = Triggering
 R = Output circuit
 ⇒ = switches...

CIM1R

Time relay with mechanical change-over output contact 8 time functions + stepping function, ON-OFF switch, 50 ms ... 60 h

Type: CIM1R/UC24-240V

Sophisticated multifunction time relay, 1 change-over power contact with zero crossing switching (50/60 Hz), 8 time functions, stepping function and service function ON/OFF, time ranges: 50 ms ... 60 h, multifunction LED state indicator, suitable for any time-control application and also staircase lighting, Light-switch neon lamp current absorption on input B1, Manual switching function for maintenance, emergency, etc., 16.6 Hz power supply applications. Railway version available.

Maximum contact load	16 A / 250 V AC-1
Recommended minimum contact load	10 mA / 10 V

Time functions and related connection diagrams (Function diagrams: refer to page 20)
The functions are selectable by rotary switch

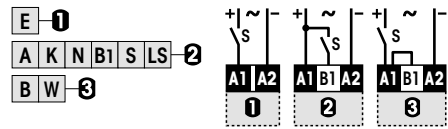

LED function table:

LED	Relay	Time run
OFF	OFF	NO
Continuous ON	ON	NO
Short blinking	OFF	YES
Long blinking	ON	YES

Time data

7 partial time ranges, t_{max} (rotary switch)	0.6, 6, 60 s / 6, 60 min / 6, 60 h
Fine adjustment range (rotary knob)	$t_{min} \dots t_{max}$, 0.5 ... 6
Time range tolerance	t_{min} : -5 % ... +0 % / t_{max} : -0 % ... +5 %
Repetition accuracy	± 0.1 % or DC: 2 ms / AC: 10 ms
Response time, power on, on A1	≤ 45 ms
Min. trigger pulse on B1	20 ms (AC / DC)
Reset time B1 (AC/DC)	≤ 40 ms
Voltage failure buffering (50 / 60 Hz)	≥ 20 ms

Contacts

Type	AgNi / 1 CO, micro disconnection
Rated operational current at 40 °C / 60 °C	16 A / 13 A
Max. inrush current (10 ms)	30 A
Max. switching voltage AC-1	250 V
Max. AC load AC-1 (Fig.1)	4 kVA
Max. DC load DC-1	see Fig. 2

Power supply- and control input

Nominal voltage (A1, B1)	UC 24-240 V (UC = AC/DC)
Operating voltage range	UC 16.8 ... 250 V
Power consumption	approx. 0.5 W
Frequency range	16 ... 63 Hz
Allowed DC residual current into B1	≤ 0.5 mA
AC Neon lamp residual current into B1	≤ 10 mA
Trigger threshold voltage on B1, AC / DC	13 / 15 V

Insulation

Test voltage open contact	1 kVrms 1 minute
Test voltage between contacts and control input	2.5 kVrms 1 minute

General Specifications

Ambient temperature storage / operation	-40 ... +85 °C / -40 ... +70 °C
Mechanical life of contact	30 x 10 ⁶ operations
Conductor cross section	Stranded wire 2.5 mm ² , 2 x 1.5 mm ²
Ingress protection rating	IP 20
Max. Screw torque	0.4 Nm
Housing material	Lexan
Weight	70 g

Standard types

UC (AC/DC) 15...60 Hz	CIM1R/UC24-240V
------------------------------	------------------------

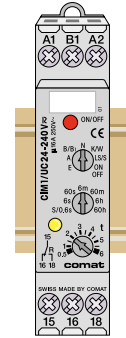

Connection diagram

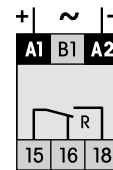

Fig. 1 AC voltage endurance

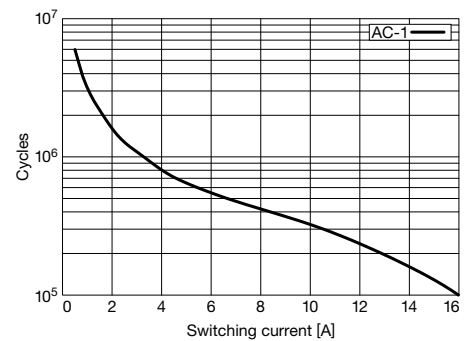
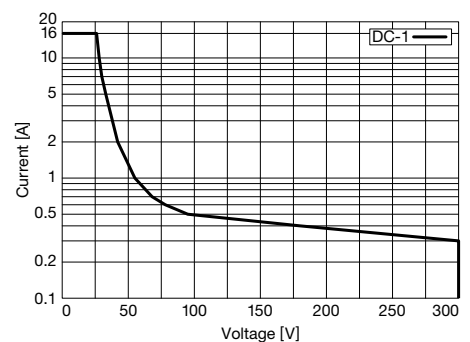
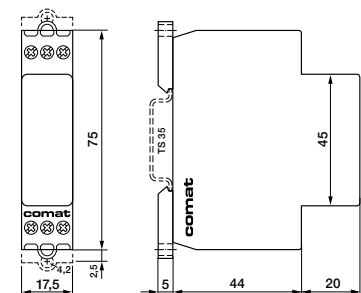

Fig. 2 DC load limit curve



Dimensions [mm]



Technical approvals, conformities

See table on page 53.

CIM12R

Time relay with AC solid-state output

8 time functions and stepping function, ON-OFF switch, 50 ms ... 60 h

Type: CIMR12R/UC24-240V

Sophisticated multifunction time relay, 1 triac output, suitable for high frequency of operations and inductive loads, 8 time functions, stepping function and service function ON/OFF, time ranges: 50 ms ... 60 h, multifunction LED state indicator, suitable for any time-control application and also staircase lighting, Light-switch neon lamp current absorption on input B1, manual switching function for maintenance, emergency, etc., 16.6 Hz applications. Railway version available.

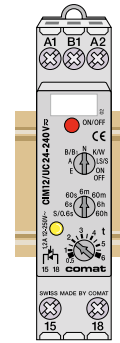

Maximum contact load	2 A / 250 V
Minimum contact load	50 mA

Time functions and related connection diagrams (Function diagrams: refer to page 20)

The functions are selectable by rotary switch

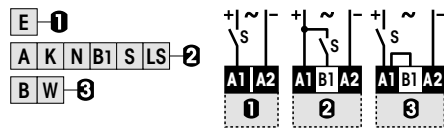

LED function table:

LED	Relay	Time run
OFF	OFF	NO
Continuous ON	ON	NO
Short blinking	OFF	YES
Long blinking	ON	YES

Time data

7 partial time ranges, t_{max} (rotary switch)	0.6, 6, 60 s / 6, 60 min / 6, 60 h
Fine adjustment range (rotary knob)	$t_{min} \dots t_{max}$, 0.5 ... 6
Time range tolerance	t_{min} : -5 % ... +0 % / t_{max} : -0 % ... +5 %
Repetition accuracy	± 0.1 % or DC: 2 ms / AC: 10 ms
Response time, power on, on A1	≤ 45 ms
Min. trigger pulse on B1	20 ms (AC / DC)
Reset time B1 (AC/DC)	≤ 40 ms
Voltage failure buffering (50 / 60 Hz)	≥ 20 ms

Output

Type	Triac, zero crossing
Rated operational current at 40 °C (Fig.1)	2 A
Max. inrush current (10 ms)	100 A
Max. switching voltage	250 V
Max. AC load AC-1	300 VA
I ² t value	78 A ² s
Leakage current	< 1 mA

Power supply- and control input

Nominal voltage	UC 24-240 V (UC = AC/DC)
Operating voltage range	UC 16.8 ... 250 V
Power consumption	approx. 0.5 W
Frequency range	16 ... 63 Hz
Allowed DC residual current into B1	≤ 0.5 mA
AC Neon lamp residual current into B1	≤ 10 mA
Trigger threshold voltage on B1, AC / DC	13 / 15 V

Insulation

Test voltage between output and control input	2.5 kVrms 1 minute
---	--------------------

General Specifications

Ambient temperature storage / operation	-40 ... +85 °C / -40 ... +70 °C
Conductor cross section	Stranded wire 2.5 mm ² , 2 x 1.5 mm ²
Ingress protection rating	IP 20
Max. Screw torque	0.4 Nm
Housing material	Lexan
Weight	70 g

Standard types

UC (AC/DC), 15...60 Hz CIM12R/UC24-240V

Connection diagram

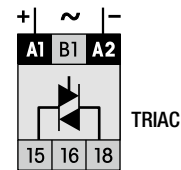
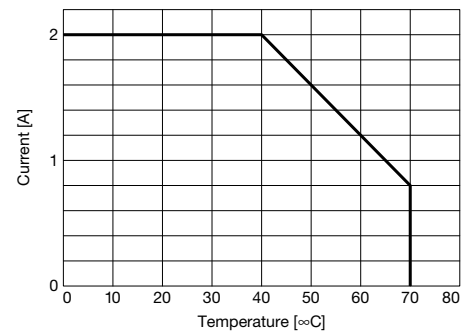
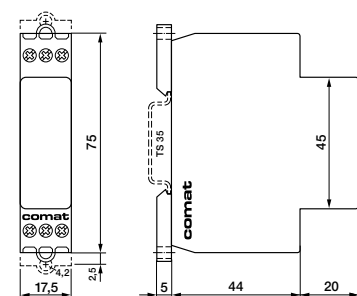

Fig. 1 Output derating curve



Dimensions [mm]



Technical approvals, conformities

See table on page 53.

CIM13R

Time relay with DC solid-state output

8 time functions and stepping function, ON-OFF switch, 50 ms ... 60 h

Type: CIM13R/UC24-240V

Sophisticated multifunction time relay, 1 transistor output, 8 time functions, stepping function and service function ON/OFF, time ranges from 50 ms ... 60 h, multifunction LED state indicator, suitable for any time-control application and also staircase-light control, light-switch neon lamp current absorption on input B1, manual switching function for maintenance, emergency, etc., 16.6 Hz applications. Railway version available.

Maximum contact load	5 A / 30 V
Recommended minimum contact load	1 mA

Time functions and related connection diagrams (Function diagrams: refer to page 20)
The functions are selectable by rotary switch

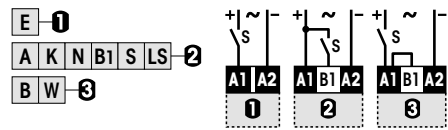

LED function table:

LED	Relay	Time run
OFF	OFF	NO
Continuous ON	ON	NO
Short blinking	OFF	YES
Long blinking	ON	YES

Time data

7 partial time ranges, t_{max} (rotary switch)	0.6, 6, 60 s / 6, 60 min / 6, 60 h
Fine adjustment range (rotary knob)	$t_{min} \dots t_{max}, 0.5 \dots 6$
Time range tolerance	$t_{min}: -5 \% \dots +0 \% / t_{max}: -0 \% \dots +5 \%$
Repetition accuracy	$\pm 0.1 \%$ or DC: 2 ms / AC: 10 ms
Response time, power on, on A1	≤ 45 ms
Min. trigger pulse on B1	20 ms (AC / DC)
Reset time B1 (AC/DC)	≤ 40 ms
Voltage failure buffering (50 / 60 Hz)	≥ 20 ms

Output

Type	MOS FET
Rated operational current at 40 °C (Fig.1)	5 A
Max. inrush current (10 μ s)	40 A
Max. switching voltage	30 V
Leakage current	$< 10 \mu$ A

Power supply- and control input

Nominal voltage (UC = AC / DC)	UC 24-240 V (UC = AC/DC)
Operating voltage range	UC 16.8 ... 250 V
Power consumption	approx. 0.5 W
Frequency range	16 ... 63 Hz
Allowed DC residual current into B1	≤ 0.5 mA
AC Neon lamp residual current into B1	≤ 10 mA
Trigger threshold voltage on B1, AC / DC	13 / 15 V

Insulation

Test voltage between output and control input	2.5 kVrms 1 minute
---	--------------------

General Specifications

Ambient temperature storage / operation	-40 ... +85 °C / -40 ... +70 °C
Conductor cross section	Stranded wire 2.5 mm ² , 2 x 1.5 mm ²
Ingress protection rating	IP 20
Max. Screw torque	0.4 Nm
Housing material	Lexan
Weight	70 g

Standard types

UC (AC/DC), 15...60 Hz

CIM13R/UC24-240V

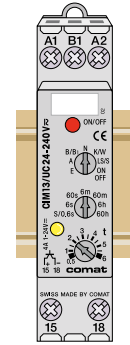

Connection diagram

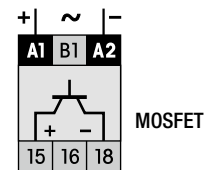
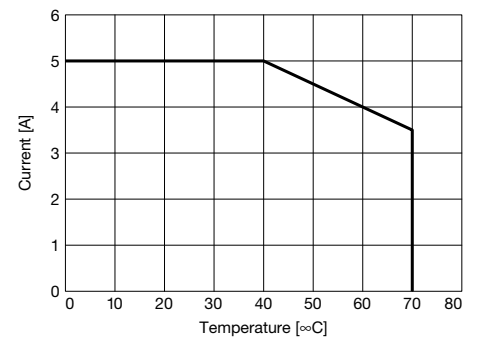
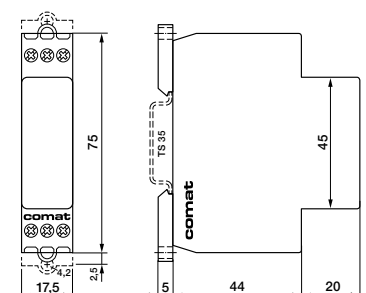

Fig. 1 Output derating curve



Dimensions [mm]



Technical approvals, conformities

See table on page 53.

CIM2R

Time relay with mechanical change-over output contact 7 time functions and 7 time ranges from 50 ms ... 60 h



Type: CIM2R/UC24-240V

Sophisticated multifunction time relay, 1 change-over power contact switching in zero crossing (50/60 Hz), 7 time functions and service function ON/OFF, 7 time ranges from 50 ms to 60 h, multifunction LED state indicator, suitable for any time-control application, light-switch neon lamp current absorption on input B1, manual switching function for maintenance, emergency, etc., 16.6 Hz power supply applications. Railway version available.

Maximum contact load	16 A / 250 V AC-1
Recommended minimum contact load	10 mA / 10 V

Time functions and related connection diagrams (Function diagrams: refer to page 20)
The functions are selectable by rotary switch

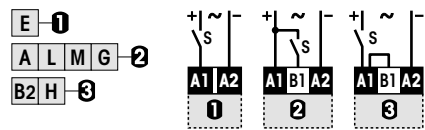

LED function table:

LED	Relay	Time run
OFF	OFF	NO
Continuous ON	ON	NO
Short blinking	OFF	YES
Long blinking	ON	YES

Time data

7 partial time ranges, t_{max} (rotary switch)	0.6, 6, 60 s / 6, 60 min / 6, 60 h
Fine adjustment range (rotary knob)	$t_{min} \dots t_{max}, 0.5 \dots 6$
Time range tolerance	$t_{min}: -5 \% \dots +0 \% / t_{max}: -0 \% \dots +5 \%$
Repetition accuracy	$\pm 0.1 \%$ or DC: 2 ms / AC: 10 ms
Response time, power on, on A1	≤ 45 ms
Min. trigger pulse on B1	20 ms (AC / DC)
Reset time B1 (AC/DC)	≤ 40 ms
Voltage failure buffering (50 / 60 Hz)	≥ 20 ms

Contacts

Type	AgNi / 1 CO, micro disconnection
Rated operational current at 40 °C / 60 °C	16 A / 13 A
Max. inrush current (10 ms)	30 A
Max. switching voltage AC-1	250 V
Max. AC load AC-1 (Fig.1)	4 kVA
Max. DC load DC-1	see Fig. 2

Power supply- and control input

Nominal voltage (A1, B1)	UC 24-240 V (UC = AC / DC)
Operating voltage range	UC 16.8 ... 250 V
Power consumption	approx. 0.5 W
Frequency range	16 ... 63 Hz
Allowed DC residual current into B1	≤ 0.5 mA
AC Neon lamp residual current into B1	≤ 10 mA
Trigger threshold voltage on B1, AC / DC	13 / 15 V

Insulation

Test voltage open contact	1 kVrms 1 minute
Test voltage between contacts and control input	2.5 kVrms 1 minute

General Specifications

Ambient temperature storage / operation	-40 ... +85 °C / -40 ... +70 °C
Mechanical life of contact	30 x 10 ⁶ operations
Conductor cross section	Stranded wire 2.5 mm ² , 2 x 1.5 mm ²
Ingress protection rating	IP 20
Max. Screw torque	0.4 Nm
Housing material	Lexan
Weight	70 g

Standard types

UC (AC/DC) 15...60 Hz	CIM2R/UC24-240V
------------------------------	------------------------

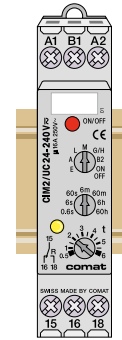

Connection diagram

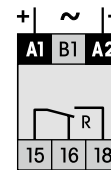

Fig. 1 AC voltage endurance

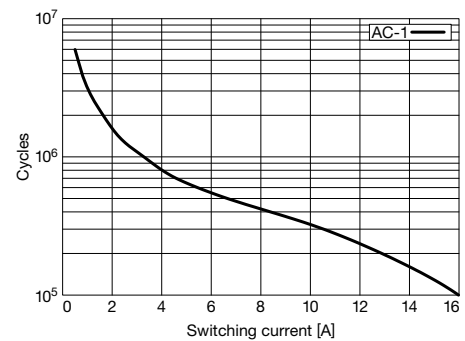
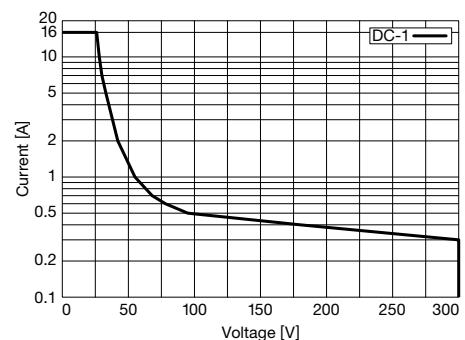
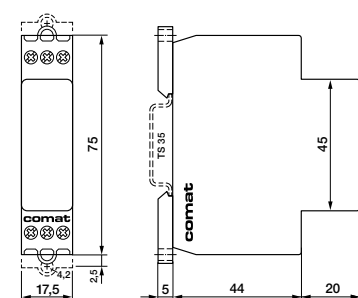

Fig. 2 DC load limit curve



Dimensions [mm]



Technical approvals, conformities

See table on page 53.

CIM22R

Time relay with AC solid-state output 7 time functions and 7 time ranges 50 ms ... 60 h

Type: CIM22R/UC24-240V

Sophisticated multifunction time relay, 1 triac output, suitable for high frequency of operations and inductive loads, 7 time functions and service function ON/OFF, 7 time ranges from 50 ms ... 60 h, multifunction LED state indicator, suitable for any time-control application light-switch neon lamp current absorption on input B1, manual switching function for maintenance, emergency, etc., 16.6 Hz applications. Railway version available.

Maximum contact load 2 A / 250 V
Minimum contact load 50 mA

Time functions and related connection diagrams (Function diagrams: refer to page 20)
The functions are selectable by rotary switch

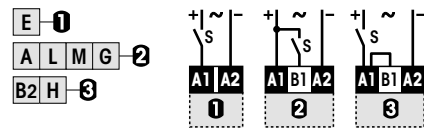

LED function table:

LED	Relay	Time run
OFF	OFF	NO
Continuous ON	ON	NO
Short blinking	OFF	YES
Long blinking	ON	YES

Time data

7 partial time ranges, t_{max} (rotary switch) 0.6, 6, 60 s / 6, 60 min / 6, 60 h
 Fine adjustment range (rotary knob) $t_{min} \dots t_{max}$, 0.5 ... 6
 Time range tolerance t_{min} : -5 % ... +0 % / t_{max} : -0 % ... +5 %
 Repetition accuracy ± 0.1 % or DC: 2 ms / AC: 10 ms
 Response time, power on, on A1 ≤ 45 ms
 Min. trigger pulse on B1 20 ms (AC / DC)
 Reset time B1 (AC/DC) ≤ 40 ms
 Voltage failure buffering (50 / 60 Hz) ≥ 20 ms

Output

Type Triac, zero crossing
 Rated operational current at 40 °C (Fig.1) 2 A
 Max. inrush current (10 ms) 100 A
 Max. switching voltage 250 V
 Max. AC load AC-1 300 VA
 I^2t value 78 A²s
 Leakage current < 1 mA

Power supply- and control input

Nominal voltage **UC 24-240 V (UC = AC / DC)**
 Operating voltage range UC 16.8 ... 250 V
 Power consumption approx. 0.5 W
 Frequency range 16 ... 63 Hz
 Allowed DC residual current into B1 ≤ 0.5 mA
 AC Neon lamp residual current into B1 ≤ 10 mA
 Trigger threshold voltage on B1, AC / DC 13 / 15 V

Insulation

Test voltage between output and control input 2.5 kVrms 1 minute

General Specifications

Ambient temperature storage / operation -40 ... +85 °C / -40 ... +70 °C
 Conductor cross section Stranded wire 2.5 mm², 2 x 1.5 mm²
 Ingress protection rating IP 20
 Max. Screw torque 0.4 Nm
 Housing material Lexan
 Weight 70 g

Standard types

UC (AC/DC), 15...60 Hz **CIM22R/UC24-240V**

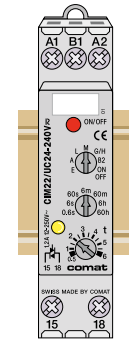

Connection diagram

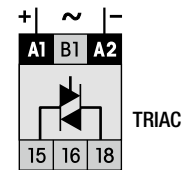
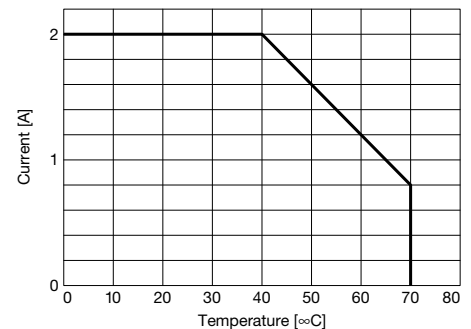
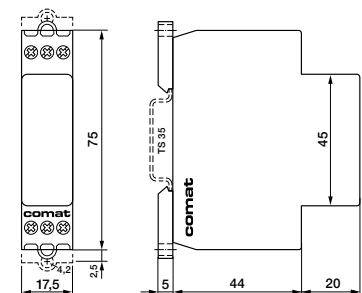

Fig. 1 Output derating curve



Dimensions [mm]



Technical approvals, conformities

See table on page 53.

CIM23R

Time relay with DC solid-state output

7 time functions and 7 time ranges from 50 ms ... 60 h

Type: CIM23R/UC24-240V

Sophisticated multifunction time relay, 1 transistor output, 7 time functions and service function ON/OFF, 7 time ranges from 50 ms ... 60 h, multifunction LED state indicator suitable for any time-control application, light-switch neon lamp current absorption on input B1, manual switching function for maintenance, emergency, etc., 16.6 Hz applications. Railway version available.

Maximum contact load 5 A / 30 V
Recommended minimum contact load 1 mA

Time functions and related connection diagrams (Function diagrams: refer to page 20)
 The functions are selectable by rotary switch

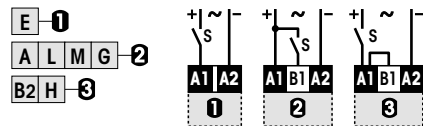

LED function table:

LED	Relay	Time run
OFF	OFF	NO
Continuous ON	ON	NO
Short blinking	OFF	YES
Long blinking	ON	YES

Time data

7 partial time ranges, t_{max} (rotary switch) 0.6, 6, 60 s / 6, 60 min / 6, 60 h
 Fine adjustment range (rotary knob) $t_{min} \dots t_{max}$, 0.5 ... 6
 Time range tolerance t_{min} : -5 % ... +0 % / t_{max} : -0 % ... +5 %
 Repetition accuracy ± 0.1 % or DC: 2 ms / AC: 10 ms
 Response time, power on, on A1 ≤ 45 ms
 Min. trigger pulse on B1 20 ms (AC / DC)
 Reset time B1 (AC/DC) ≤ 40 ms
 Voltage failure buffering (50 / 60 Hz) ≥ 20 ms

Output

Type MOS FET
 Rated operational current at 40 °C (Fig.1)) 5 A
 Max. inrush current (10 μ s) 40 A
 Max. switching voltage 30 V
 Leakage current $< 10 \mu$ A

Power supply- and control input

Nominal voltage (UC = AC / DC) **UC 24-240 V (UC = AC / DC)**
 Operating voltage range UC 16.8 ... 250 V
 Power consumption approx. 0.5 W
 Frequency range 16 ... 63 Hz
 Allowed DC residual current into B1 ≤ 0.5 mA
 AC Neon lamp residual current into B1 ≤ 10 mA
 Trigger threshold voltage on B1, AC / DC 13 / 15 V

Insulation

Test voltage between output and control input 2.5 kVrms 1 minute

General Specifications

Ambient temperature storage / operation -40 ... +85 °C / -40 ... +70 °C
 Conductor cross section Stranded wire 2.5 mm², 2 x 1.5 mm²
 Ingress protection rating IP 20
 Max. Screw torque 0.4 Nm
 Housing material Lexan
 Weight 70 g

Standard types

UC (AC/DC), 15...60 Hz **CIM23R/UC24-240V**

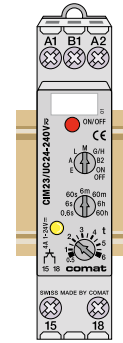

Connection diagram

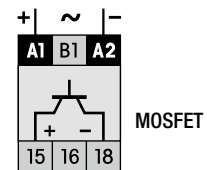
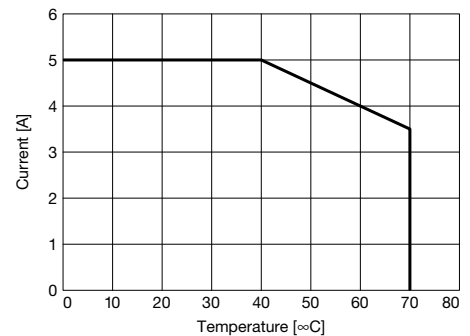
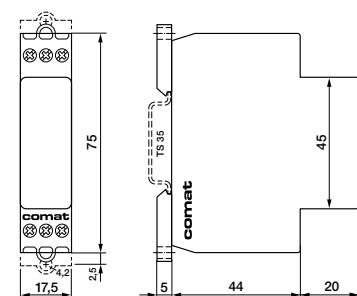

Fig. 1 Output derating curve



Dimensions [mm]



Technical approvals, conformities

See table on page 53.

CIM3R

Time relay with mechanical change-over output contact

6 time functions and service function, 7 time ranges from 50 ms...60 h

Type: CIM3R/UC24-240V

Sophisticated multifunction time relay, 1 change-over power contact switching in zero crossing (50/60 Hz), 6 time functions and service function ON/OFF, 7 time ranges from 50 ms to 60 h, multifunction LED state indicator, suitable for any time-control application, light-switch neon lamp current absorption on input B1, manual switching function for maintenance, emergency, etc., 16.6 Hz power supply applications. Railway version available.

Maximum contact load	16 A / 250 V AC-1
Recommended minimum contact load	10 mA / 10 V

Time functions and related connection diagrams (Function diagrams: refer to page 20)
The functions are selectable by rotary switch

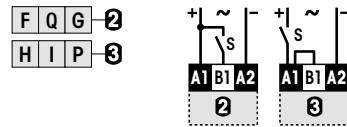

LED function table:

LED	Relay	Time run
OFF	OFF	NO
Continuous ON	ON	NO
Short blinking	OFF	YES
Long blinking	ON	YES

Time data

7 partial time ranges, t_{max} (rotary switch)	0.6, 6, 60 s / 6, 60 min / 6, 60 h
Fine adjustment range (rotary knob)	$t_{min} \dots t_{max}$, 0.5 ... 6
Time range tolerance	t_{min} : -5 % ... +0 % / t_{max} : -0 % ... +5 %
Repetition accuracy	± 0.1 % or DC: 2 ms / AC: 10 ms
Response time, power on, on A1	≤ 45 ms
Min. trigger pulse on B1	20 ms (AC / DC)
Reset time B1 (AC/DC)	≤ 40 ms
Voltage failure buffering (50 / 60 Hz)	≥ 20 ms

Contacts

Type	AgNi / 1 CO, micro disconnection
Rated operational current at 40 °C / 60 °C	16 A / 13 A
Max. inrush current (10 ms)	30 A
Max. switching voltage AC-1	250 V
Max. AC load AC-1 (Fig. 1)	4 kVA
Max. DC load DC-1	see Fig. 2

Power supply- and control input

Nominal voltage (A1, B1)	UC 24-240 V (UC = AC / DC)
Operating voltage range	UC 16.8 ... 250 V
Power consumption	approx. 0.5 W
Frequency range	16 ... 63 Hz
Allowed DC residual current into B1	≤ 0.5 mA
AC Neon lamp residual current into B1	≤ 10 mA
Trigger threshold voltage on B1, AC / DC	13 / 15 V

Insulation

Test voltage open contact	1 kVrms 1 minute
Test voltage between contacts and control input	2.5 kVrms 1 minute

General Specifications

Ambient temperature storage / operation	-40 ... +85 °C / -40 ... +70 °C
Mechanical life of contact	30 x 10 ⁶ operations
Conductor cross section	Stranded wire 2.5 mm ² , 2 x 1.5 mm ²
Ingress protection rating	IP 20
Max. Screw torque	0.4 Nm
Housing material	Lexan
Weight	70 g

Standard types

UC (AC/DC) 15...60 Hz	CIM3R/UC24-240V
------------------------------	------------------------

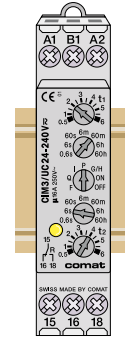

Connection diagram

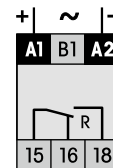

Fig. 1 AC voltage endurance

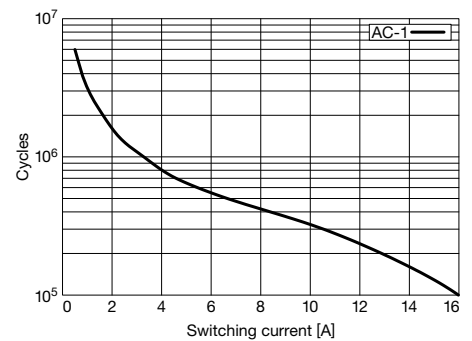
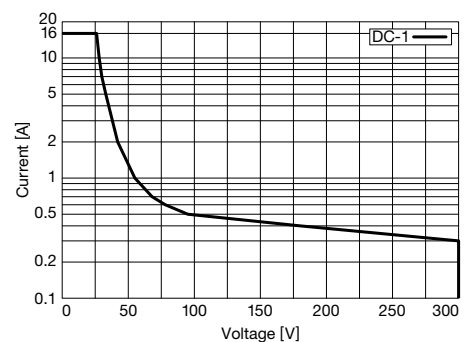
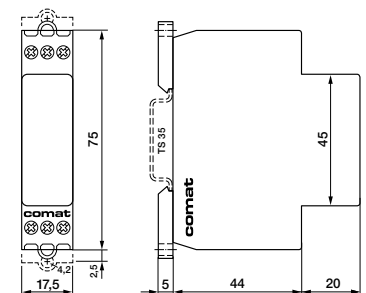

Fig. 2 DC load limit curve



Dimensions [mm]



Technical approvals, conformities

See table on page 53.

CIM32R

Time relay with AC solid-state output

6 time functions and service function, 7 time ranges from 50 ms...60 h

Type: CIM32R/UC24-240V

Sophisticated multifunction time relay, 1 triac output, suitable for high frequency of operations and inductive loads, 6 time functions and service function ON/OFF, 7 time ranges from 50 ms ... 60 h, multifunction LED state indicator, suitable for any time-control application light-switch neon lamp current absorption on input B1, manual switching function for maintenance, emergency, etc., 16.6 Hz applications. Railway version available.

Maximum contact load	2 A / 250 V
Minimum contact load	50 mA

Time functions and related connection diagrams (Function diagrams: refer to page 20)

The functions are selectable by rotary switch

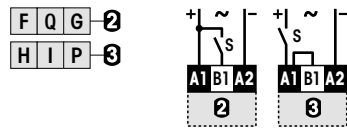

LED function table:

LED	Relay	Time run
OFF	OFF	NO
Continuous ON	ON	NO
Short blinking	OFF	YES
Long blinking	ON	YES

Time data

7 partial time ranges, t_{max} (rotary switch)	0.6, 6, 60 s / 6, 60 min / 6, 60 h
Fine adjustment range (rotary knob)	$t_{min} \dots t_{max}, 0.5 \dots 6$
Time range tolerance	$t_{min}: -5 \% \dots +0 \% / t_{max}: -0 \% \dots +5 \%$
Repetition accuracy	$\pm 0.1 \%$ or DC: 2 ms / AC: 10 ms
Response time, power on, on A1	≤ 45 ms
Min. trigger pulse on B1	20 ms (AC / DC)
Reset time B1 (AC/DC)	≤ 40 ms
Voltage failure buffering (50 / 60 Hz)	≥ 20 ms

Output

Type	Triac, zero crossing
Rated operational current at 40 °C (Fig.1)	2 A
Max. inrush current (10 ms)	100 A
Max. switching voltage	250 V
Max. AC load AC-1	300 VA
I^2t value	78 A ² s
Leakage current	< 1 mA

Power supply- and control input

Nominal voltage	UC 24-240 V (UC = AC / DC)
Operating voltage range	UC 16.8 ... 250 V
Power consumption	approx. 0.5 W
Frequency range	16 ... 63 Hz
Allowed DC residual current into B1	≤ 0.5 mA
AC Neon lamp residual current into B1	≤ 10 mA
Trigger threshold voltage on B1, AC / DC	13 / 15 V

Insulation

Test voltage between output and control input	2.5 kVrms 1 minute
---	--------------------

General Specifications

Ambient temperature storage / operation	-40 ... +85 °C / -40 ... +70 °C
Conductor cross section	Stranded wire 2.5 mm ² , 2 x 1.5 mm ²
Ingress protection rating	IP 20
Max. Screw torque	0.4 Nm
Housing material	Lexan
Weight	70 g

Standard types

UC (AC/DC), 15...60 Hz	CIM32R/UC24-240V
-------------------------------	-------------------------

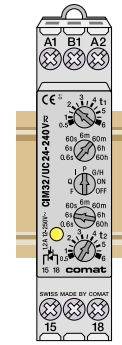

Connection diagram

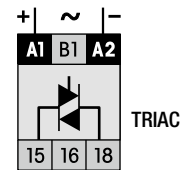
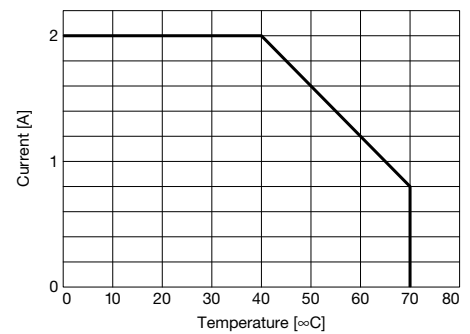
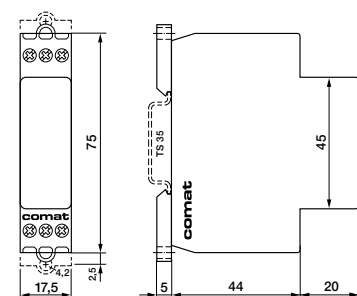

Fig. 1 Output derating curve



Dimensions [mm]



Technical approvals, conformities

See table on page 53.

CIM33R

Time relay with DC solid-state output

6 time functions and service function, 7 time ranges from 50 ms...60 h

Type: CIM33/UC24-240V

Sophisticated multifunction time relay, 1 transistor output, 6 time functions and service function ON/OFF, 7 time ranges from 50 ms ... 60 h, Multifunction LED state indicator, suitable for any time-control application, light-switch neon lamp current absorption on input B1, manual switching function for maintenance emergency, etc., 16.6 Hz applications. Railway version available.

Maximum contact load 5 A / 30 V
Recommended minimum contact load 1 mA

Time functions and related connection diagrams (Function diagrams: refer to page 20)

The functions are selectable by rotary switch

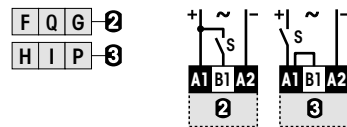

LED function table:

LED	Relay	Time run
OFF	OFF	NO
Continuous ON	ON	NO
Short blinking	OFF	YES
Long blinking	ON	YES

Time data

7 partial time ranges, t_{max} (rotary switch) 0.6, 6, 60 s / 6, 60 min / 6, 60 h
 Fine adjustment range (rotary knob) $t_{min} \dots t_{max}$, 0.5 ... 6
 Time range tolerance t_{min} : -5 % ... +0 % / t_{max} : -0 % ... +5 %
 Repetition accuracy ± 0.1 % or DC: 2 ms / AC: 10 ms
 Response time, power on, on A1 ≤ 45 ms
 Min. trigger pulse on B1 20 ms (AC / DC)
 Reset time B1 (AC/DC) ≤ 40 ms
 Voltage failure buffering (50 / 60 Hz) ≥ 20 ms

Output

Type MOS FET
 Rated operational current at 40 °C (Fig.1) 5 A
 Max. inrush current (10 μ s) 40 A
 Max. switching voltage 30 V
 Leakage current $< 10 \mu$ A

Power supply- and control input

Nominal voltage **UC 24-240 V (UC = AC / DC)**
 Operating voltage range UC 16.8 ... 250 V
 Power consumption approx. 0.5 W
 Frequency range 16 ... 63 Hz
 Allowed DC residual current into B1 ≤ 0.5 mA
 AC Neon lamp residual current into B1 ≤ 10 mA
 Trigger threshold voltage on B1, AC / DC 13 / 15 V

Insulation

Test voltage between output and control input 2.5 kVrms 1 minute

General Specifications

Ambient temperature storage / operation -40 ... +85 °C / -40 ... +70 °C
 Conductor cross section Stranded wire 2.5 mm², 2 x 1.5 mm²
 Ingress protection rating IP 20
 Max. Screw torque 0.4 Nm
 Housing material Lexan
 Weight 70 g

Standard types

UC (AC/DC), 15...60 Hz **CIM33R/UC24-240V**

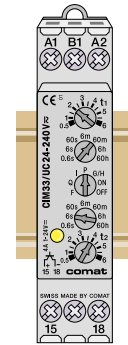

Connection diagram

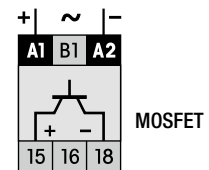
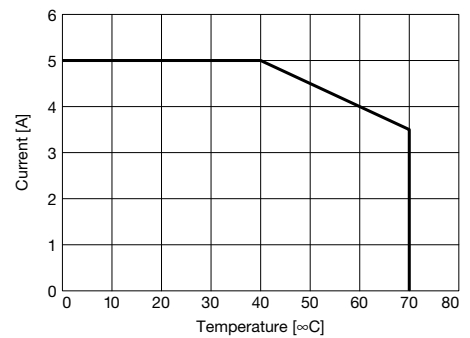
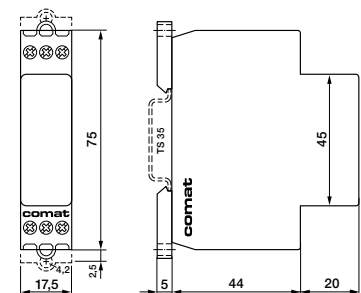

Fig. 1 Output derating curve



Dimensions [mm]



Technical approvals, conformities

See table on page 53.

CT32R, CT33R, CT36R

Type CT32R, CT33R, CT36R, /...V

Plug-in time modules for sockets with module slot in combination with plug-in relays.
 Power supply and control voltages 24 ... 240 V. Time ranges 30 ms up to 60 h.
 LED output state indicator.

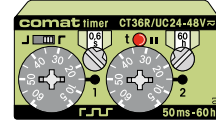

Time functions and related connection diagrams (Function diagrams: refer to page 20)

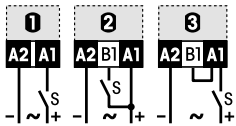

CT32R (Universal)

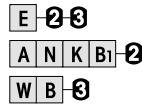

CT33R (Universal)

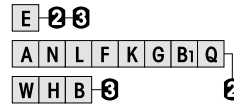

CT36R (Repeat cycle timer)



Time data

	CT32R	CT33R	CT36R
Type	CT32R	CT33R	CT36R
Partial time ranges, t_{max}	1.5, 6, 15, 60 /s /min	150, 600 ms 1.5, 6, 15, 60 /s /min /h	2 x 600 ms 2 x 6, 60 /s /min /h
Min. time t_{min}	0.15 s	30 ms	2 x 50 ms
Fine adj. range t_{min} ...	1 ... 1 0	0.2 ... 1	2 x 5 ... 60
Time range tolerance	-25 ... 0 % 0 ... 25 %	-25 ... 0 % 0 ... 25 %	-25 ... 0 % 0 ... 25 %
Repetition accuracy	± 0.2 % or 20 ms	± 0.2 % or 20 ms	± 0.2 % or 20 ms
Temperature drift of time	0.1 % / K	0.1 % / K	0.1 % / K
Min. trigger pulse width B1	≥ 30 ms	≥ 30 ms	-
Reset time pow. supply	≤ 150 ms	≤ 150 ms	≤ 150 ms
Voltage failure buffering	≥ 20 ms	≥ 20 ms	≥ 20 ms

Output data

Nominal voltage	UC 24–48 V
Type	Solid state
Rated operational current	150 mA
On-state resistance	$\leq 25 \Omega$
Leakage current	$\leq 150 \mu A$

Power supply and control input (UC = AC/DC)

	CT32R	CT33R	CT36R
Type	CT32R	CT33R	CT36R
Nominal voltage	UC 24 – 48 V	UC 24 – 48 V	UC 24 – 48 V
Operating voltage range	16.8 ... 60 V	16.8 ... 60 V	16.8 ... 60 V
Input B1 inactive	≤ 9 V	≤ 9 V	-
Supply current	5 ... 11 mA	5 ... 11 mA	6 ... 12 mA

General Specification

Ambient temperature storage / operation	-40 ... +85 °C / -40 ... +70 °C
Ingress protection rating	IP 40 when plugged in
Housing material	Lexan
Weight	25 g

Standard types

CT32R/UC24-48V
CT33R/UC24-48V
CT36R/UC24-48V

Remark: This module is part of several ready for connection units consisting of socket, relay and module. A wide range of suitable relays are available.

Dimensions [mm]

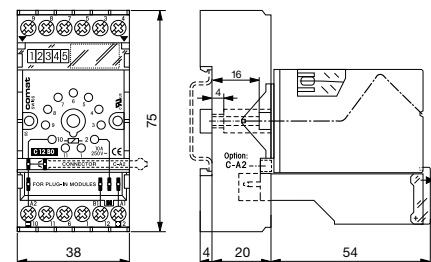

Technical approvals, conformities

See table on page 53.

CT32.31R, CT33.31R, CT36.31R
CT32.32R, CT33.32R, CT36.32R

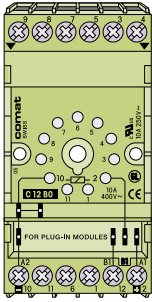

Timer Delay Relay-Set
 Relay, Module and Socket

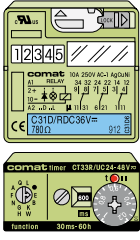

- Set delivery includes:
- Relay
 - Module
 - Front cover
 - Socket
 - Retaining clip

Power Relay

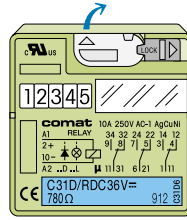
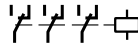

C31D/R

Universal Power Relay 10A with 3 power change-over-contacts this is the robust relay for AC and DC circuits ranging from 50mA 10V.

10A 250V~
 50mA 10V

Control Relay

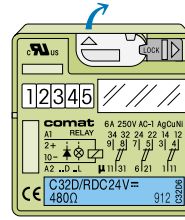
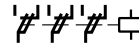

C32D/R

Relay with 3 twin contacts 6A
 The control relay with highest switching reliability for control and signal circuits ranging from 10mA 5V.

6A 250V~
 10mA 5V

Relay data:
 See page 4/5

Relay data's see:
 Relay C31; C32

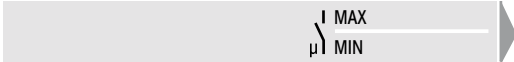

Timer-Modul

E 1 Triggering
 Function (see page 30)

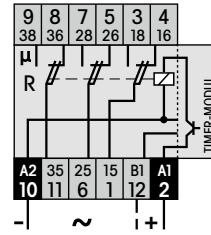
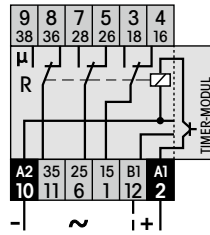
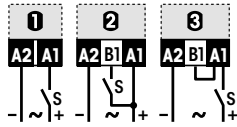

CT32R Universal-Timer

7 functions, voltage controlled, time lapse display, blinking. Seismic approved.

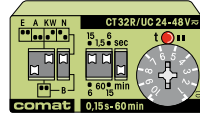

Function/Triggering

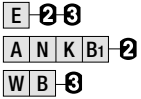

Timer Range

0,15s-60min ★
 0,15-1,5s...
 6-60min

Set Order-Nr.:

CT32.31R/...V
 DC 24, 36V

- Delivery includes:
- Relay C31D/R DC...V
 - Module CT32R/UC24-48V
 - Front cover FS-C
 - Socket C12B0
 - Retaining clip HF-32

Set Order-Nr.:

CT32.32R/...V
 DC 24, 36V

- Delivery includes:
- Relay C32D/R DC...V
 - Module CT32R/UC24-48V
 - Front cover FS-C
 - Socket C12B0
 - Retaining clip HF-32

CT33R Universal-Timer

12 functions, voltage controlled, time lapse display, blinking, high setting accuracy by dial graduation 1:5.

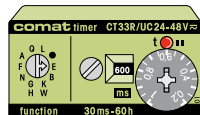

Function/Triggering

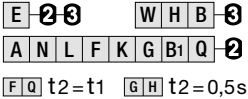

Timer Range

30ms-60h ★
 30-150ms...
 12-60h

Set Order-Nr.:

CT33.31R/...V
 DC 24, 36V

- Delivery includes:
- Relay C31D/R DC...V
 - Module CT33R/UC24-48V
 - Front cover FS-C
 - Socket C12B0
 - Retaining clip HF-32

Set Order-Nr.:

CT33.32R/...V
 DC 24, 36V

- Delivery includes:
- Relay C32D/R DC...V
 - Module CT33R/UC24-48V
 - Front cover FS-C
 - Socket C12B0
 - Retaining clip HF-32

CT36R Universal-Taktgeber

Pulse or pause start. t1/t2 separately settable. Time lapse display t1/t2.

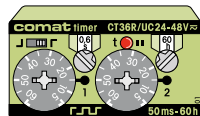

Function/Triggering



Timer Range

2x50ms-60h ★
 2x50-600ms...
 5-60h

Set Order-Nr.:

CT36.31R/...V
 DC 24, 36V

- Delivery includes:
- Relay C31D/R DC...V
 - Module CT36R/UC24-48V
 - Front cover FS-C
 - Socket C12B0
 - Retaining clip HF-32

Set Order-Nr.:

CT36.32R/...V
 DC 24, 36V

- Delivery includes:
- Relay C32D/R DC...V
 - Module CT36R/UC24-48V
 - Front cover FS-C
 - Socket C12B0
 - Retaining clip HF-32

Dimensions [mm]









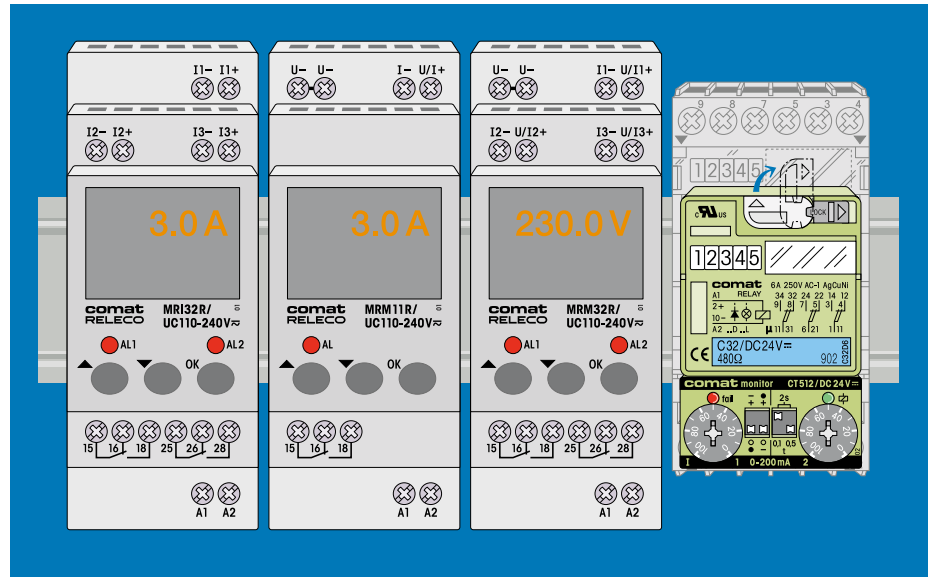













































See page 30.

Technical approvals, conformities

See table on page 53.

3. Monitoring Relays



Application	Types	Monitoring	Monitoring range	Output contacts	Design
Voltage monitoring, AC / DC single phase	MRU11R	 	0 ... AC 480 V / DC 690 V		
Voltage monitoring, AC / DC three phase	MRU32R	 	0 ... AC 480 V / DC 690 V		
Current monitoring, AC / DC single phase	MRI11R	 	0 ... 5 A		
Current monitoring, AC / DC three phase	MRI32R	 	0 ... 5 A		
Multifunction monitoring, AC / DC single phase	MRM11R	   	U, I, P, f, cos φ		
Multifunction monitoring, AC / DC three phase	MRM32R	   	U, I, P, f, cos φ		
DC Voltage monitoring	CT524.31R		0 ... 30 V		
DC Voltage monitoring	CT524.32R		0 ... 30 V		
DC Current monitoring	CT512.31R		0 ... 200 mA		
DC Current monitoring	CT512.32R		0 ... 200 mA		
DC Current monitoring	CT515.31R		0 ... 2 A		
DC Current monitoring	CT515.32R		0 ... 2 A		
DC Current monitoring	CT516.31R		0 ... 6 A		
DC Current monitoring	CT516.32R		0 ... 6 A		
Isolation monitoring, DC networks	ESU-D2		1 ... 50 kΩ		50mm

MRU11R

Voltage monitoring relay AC/DC, single phase DIN Rail mounting according to DIN 43 880



Type: MRU11R/...V

Voltage monitoring relay with over- and under voltage thresholds up to 690 V.
Alarm delay setting. Alarm LED. Display for voltmeter function, alarm signal and interactive parameter setting.
1 change-over alarm contact 6 A 250 V. Comfortable parameter setting.

Monitoring function

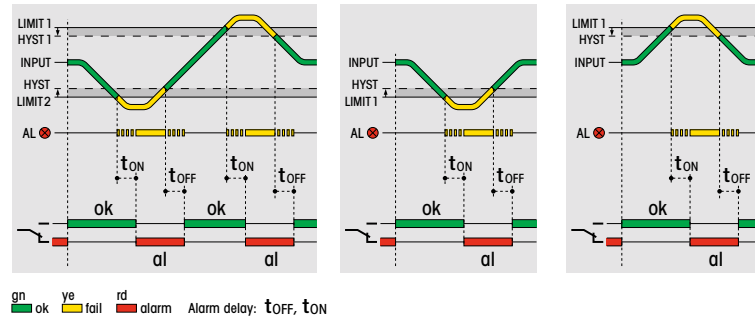

Measuring circuit data

Over/under voltage setting ranges AC / DC	0 ... 480 V / 0 ... 690 V
Frequency	DC, AC 16 ... 100 Hz
Resolution	100 mV
Accuracy	2 % ± 1 digit
Input resistance	1 MΩ

Time data

Alarm delay setting time	0.1 ... 999.9 s
Reset time setting range	0.1 ... 999.9 s
Voltage failure buffering	ca. 30 ms

Contacts

Type / Material	1 CO / AgNi 0.15
Rated operational current	6 A
Max. inrush current	15 A
Max. switching voltage	250 V
Max. AC load AC-1 (Fig.1)	1250 VA
Max. DC load DC-1, 24 V / 220 V (Fig.2)	120 W / 25 W
Recommended min. contact load	10 mA / 10 V

Power supply

	UC12-48V	UC110-240V
Nominal voltage AC/DC	12 ... 48 V	110 ... 240 V
Operating voltage range	10 ... 57 V	85 ... 250 V
AC frequency	16 ... 63 Hz	16 ... 63 Hz
Power consumption	2 W / 3 VA	2 W / 3 VA

Insulation

Test voltage open - contact	1 kVrms 1 minute
Test voltage measuring input - contacts	4 kVrms 1 minute
Test voltage measuring input - power supply	4 kVrms 1 minute

General specifications

Ambient temperature storage /operation	-40 ... +85 °C / -25 ... +60 °C
Mechanical life of contacts	30 x 10 ⁶ operations
Conductor cross section	Stranded wire 2.5 mm ² , 2 x 1.5 mm ²
Ingress protection rating	IP20
Max. screw torque	0.4 Nm
Housing material	Lexan EXL 9330
Weight	130 g

Standard types

AC/DC 12-48 V, 15...60 Hz	MRU11R/UC12-48V
AC/DC 110-240 V, 15...60 Hz	MRU11R/UC110-240V

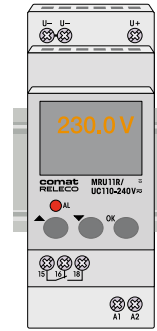

Connection diagram

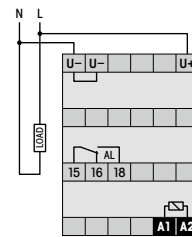

Fig. 1 AC voltage endurance

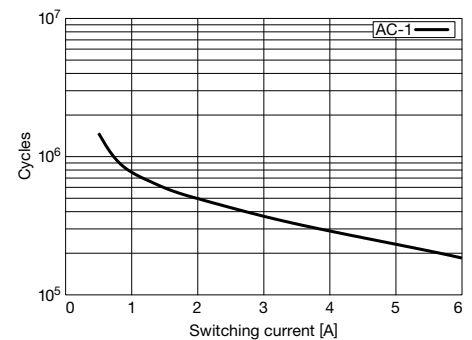
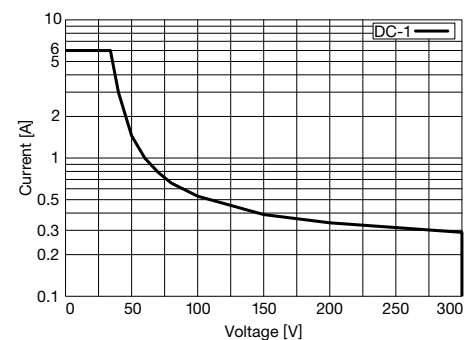
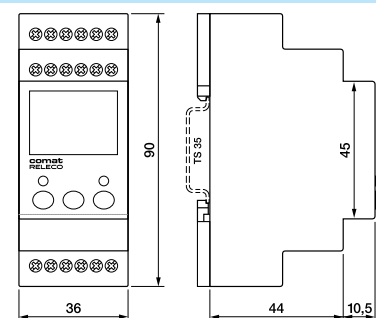

Fig. 2 DC load limit curve



Dimensions [mm]



Technical approvals, conformities

See table on page 53.

MRU32R

Voltage monitoring relay AC/DC, three phase DIN Rail mounting according to DIN 43 880

Type: MRU32R/...V

Voltage monitoring relay with over- and under voltage thresholds up to 690 V.
Alarm delay setting, Alarm LED. Display for voltmeter function, alarm signal and interactive parameter setting.
2 change-over alarm contacts 6 A 250 V. Comfortable parameter setting.

Monitoring function

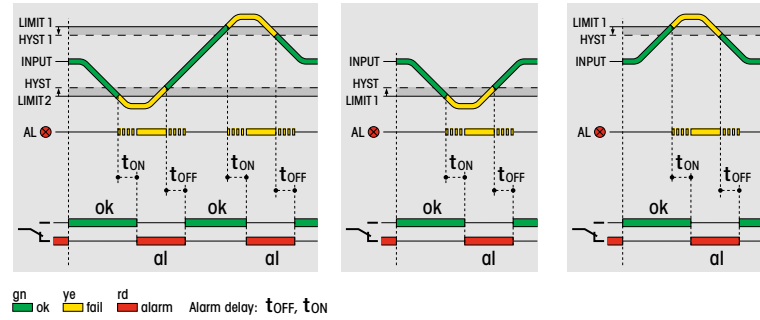

Measuring circuit data

Over/under voltage setting ranges AC / DC	0 ... 480 V / 0 ... 690 V
Frequency	DC, AC 16 ... 100 Hz
Resolution	100 mV
Accuracy	2 % ± 1 digit
Input resistance	1 MΩ

Time data

Alarm delay setting time	0.1 ... 999.9 s
Reset time setting range	0.1 ... 999.9 s
Voltage failure buffering	ca. 30 ms

Contacts

Type / Material	2 CO / AgNi 0.15
Rated operational current	6 A
Max. inrush current	15 A
Max. switching voltage	250 V
Max. AC load AC-1 (Fig.1)	1250 VA
Max. DC load DC-1, 24 V / 220 V (Fig.2)	120 W / 25 W
Recommended min. contact load	10 mA / 10 V

Power supply

	UC 12-48V	UC 110-240V
Nominal voltage AC/DC	12 ... 48 V	110 ... 240 V
Operating voltage range	10 ... 57 V	85 ... 250 V
AC frequency	16 ... 63 Hz	16 ... 63 Hz
Power consumption	2 W / 3 VA	2 W / 3 VA

Insulation

Test voltage open - contact	1 kVrms 1 minute
Test voltage between poles	2.5 kVrms 1 minute
Test voltage measuring input - contacts	4 kVrms 1 minute
Test voltage measuring input - power supply	4 kVrms 1 minute

General specifications

Ambient temperature storage /operation	-40 ... +85 °C / -25 ... +60 °C
Mechanical life of contacts	30 x 10 ⁶ operations
Conductor cross section	Stranded wire 2.5 mm ² , 2 x 1.5 mm ²
Ingress protection rating	IP20
Max. screw torque	0.4 Nm
Housing material	Lexan EXL 9330
Weight	130 g

Standard types

AC/DC 12-48 V, 15...60 Hz
AC/DC 110-240 V, 15...60 Hz

MRU32R/UC12-48V
MRU32R/UC110-240V

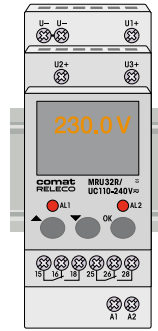

Connection diagram

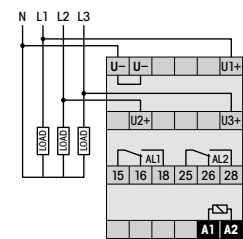

Fig. 1 AC voltage endurance

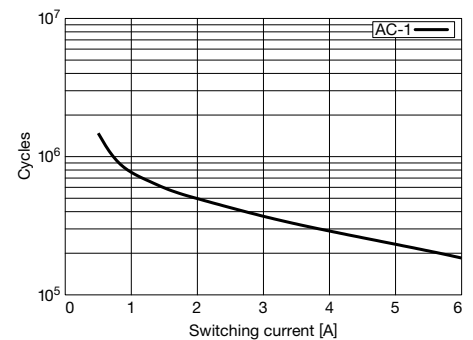
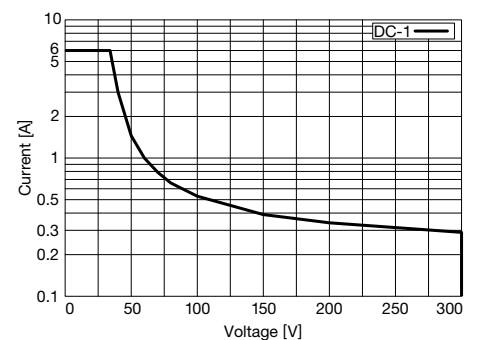
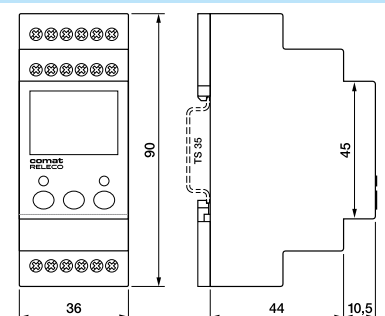

Fig. 2 DC load limit curve



Dimensions [mm]



Technical approvals, conformities

See table on page 53.

MRI11R

Current monitoring relay AC/DC, single phase DIN Rail mounting according to DIN 43 880



Type: MRI11R/...V

Current monitoring relay with over- and under voltage thresholds up to 5 A. Alarm delay setting. Alarm LED. Display for voltmeter function, alarm signal and interactive parameter setting.

1 change-over alarm contact 6 A 250 V. Comfortable parameter setting.

Monitoring function

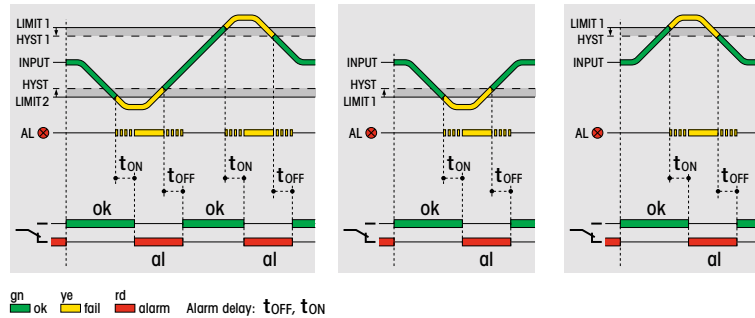

Measuring circuit data

Over-/under current setting ranges AC / DC	0 ... 5 A
Frequency	DC, AC 16 ... 100 Hz
Resolution	100 mA
Accuracy	2 % ± 1 digit
Input resistance	5 mΩ

Time data

Alarm delay setting time	0.1 ... 999.9 s
Reset time setting range	0.1 ... 999.9 s
Voltage failure buffering	ca. 30 ms

Contacts

Type / Material	1 CO / AgNi 0.15	
Rated operational current	6 A	
Max. inrush current	15 A	
Max. switching voltage	250 V	
Max. AC load AC-1 (Fig.1)	1250 VA	
Max. DC load DC-1, 24 V / 220 V (Fig.2)	120 W / 25 W	
Recommended min. contact load	10 mA / 10 V	

Power supply

	UC12-48V	UC110-240V
Nominal voltage AC/DC	12 ... 48 V	110 ... 240 V
Operating voltage range	10 ... 57 V	85 ... 250 V
AC frequency	16 ... 63 Hz	16 ... 63 Hz
Power consumption	2 W / 3 VA	2 W / 3 VA

Insulation

Test voltage open - contact	1 kVrms 1 minute
Test voltage measuring input - contacts	4 kVrms 1 minute
Test voltage measuring input - power supply	4 kVrms 1 minute

General specifications

Ambient temperature storage /operation	-40 ... +85 °C / -25 ... +60 °C
Mechanical life of contacts	30 x 10 ⁶ operations
Conductor cross section	Stranded wire 2.5 mm ² , 2 x 1.5 mm ²
Ingress protection rating	IP20
Max. screw torque	0.4 Nm
Housing material	Lexan EXL 9330
Weight	130 g

Standard types

UC 12-48 V (AC/DC), 15...60 Hz
UC 110-240 V (AC/DC), 15...60 Hz

MRI11R/UC12-48V
MRI11R/UC110-240V

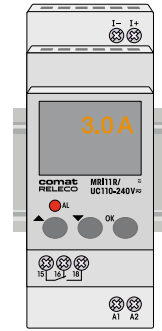

Connection diagram

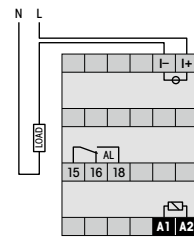

Fig. 1 AC voltage endurance

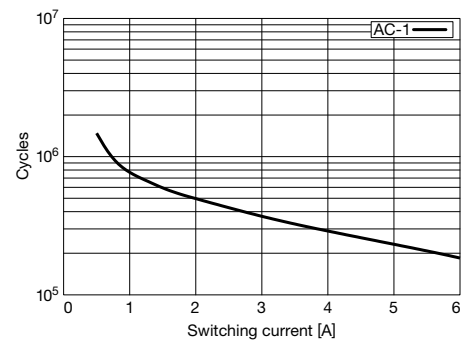
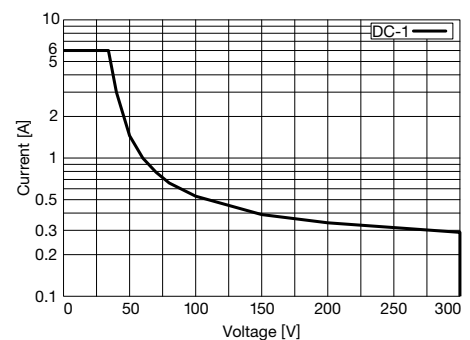
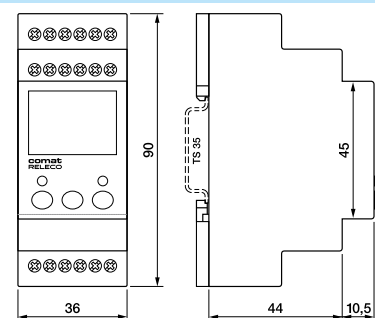

Fig. 2 DC load limit curve



Dimensions [mm]



Technical approvals, conformities

See table on page 53.

MRI32R

Current monitoring relay AC/DC, three phase DIN Rail mounting according to DIN 43 880

Type: MRI32R/...V

Current monitoring relay with over- and under current thresholds up to 5 A.
Alarm delay setting, Alarm LED. Display for voltmeter function, alarm signal and interactive parameter setting.
2 change-over alarm contacts 6 A 250 V. Comfortable parameter setting.

Monitoring function

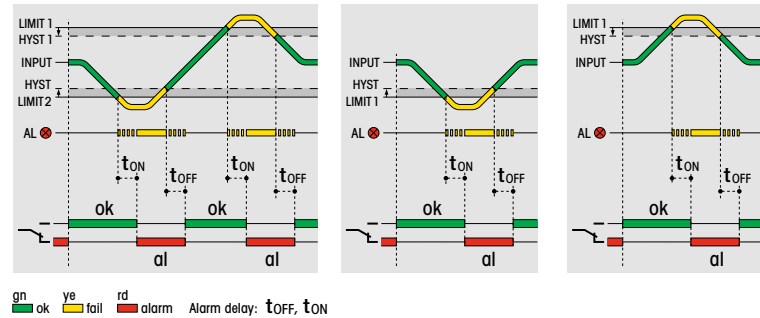

Measuring circuit data

Over/under current setting ranges AC / DC	0 ... 5 A
Frequency	DC, AC 16 ... 100 Hz
Resolution	100 mA
Accuracy	2 % ± 1 digit
Input resistance	5 mΩ

Time data

Alarm delay setting time	0.1 ... 999.9 s
Reset time setting range	0.1 ... 999.9 s
Voltage failure buffering	ca. 30 ms

Contacts

Type / Material	2 CO / AgNi 0.15
Rated operational current	6 A
Max. inrush current	15 A
Max. switching voltage	250 V
Max. AC load AC-1 (Fig.1)	1250 VA
Max. DC load DC-1, 24 V / 220 V (Fig.2)	120 W / 25 W
Recommended min. contact load	10 mA / 10 V

Power supply

	UC12-48V	UC110-240V
Nominal voltage AC/DC	12 ... 48 V	110 ... 240 V
Operating voltage range	10 ... 57 V	85 ... 250 V
AC frequency	16 ... 63 Hz	16 ... 63 Hz
Power consumption	2 W / 3 VA	2 W / 3 VA

Insulation

Test voltage open - contact	1 kVrms 1 minute
Test voltage between poles	2.5 kVrms 1 minute
Test voltage measuring input - contacts	4 kVrms 1 minute
Test voltage measuring input - power supply	4 kVrms 1 minute

General specifications

Ambient temperature storage /operation	-40 ... +85 °C / -25 ... +60 °C
Mechanical life of contacts	30 x 10 ⁶ operations
Conductor cross section	Stranded wire 2.5 mm ² , 2 x 1.5 mm ²
Ingress protection rating	IP20
Max. screw torque	0.4 Nm
Housing material	Lexan EXL 9330
Weight	130 g

Standard types

UC 12-48 V (AC/DC), 15...60 Hz
UC 110-240 V (AC/DC), 15...60 Hz

MRI32R/UC12-48V
MRI32R/UC110-240V

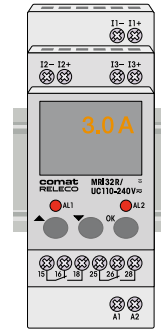

Connection diagram

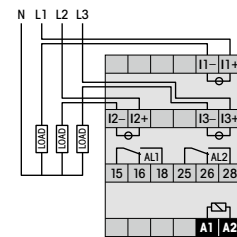

Fig. 1 AC voltage endurance

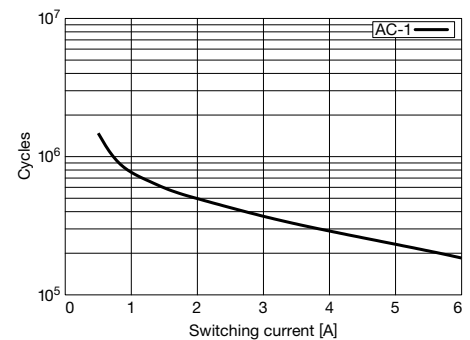
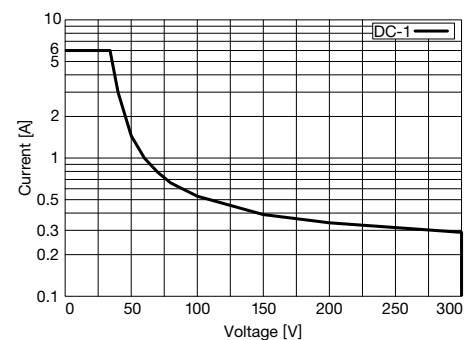
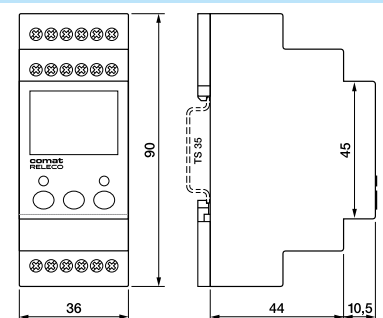

Fig. 2 DC load limit curve



Dimensions [mm]



Technical approvals, conformities

See table on page 53.

MRM11R

Multifunction monitoring relay AC/DC, single phase DIN Rail mounting according to DIN 43 880



Type: MRM11R/...V

Multifunctional monitoring relay for simultaneous measurement of current and voltage and monitoring of U, I, P, cosφ and f. Alarm delay setting. Alarm LED. Display for multimeter function, alarm signal and interactive parameter setting.

1 change-over alarm contact 6 A 250 V. Comfortable parameter setting.

Monitoring function

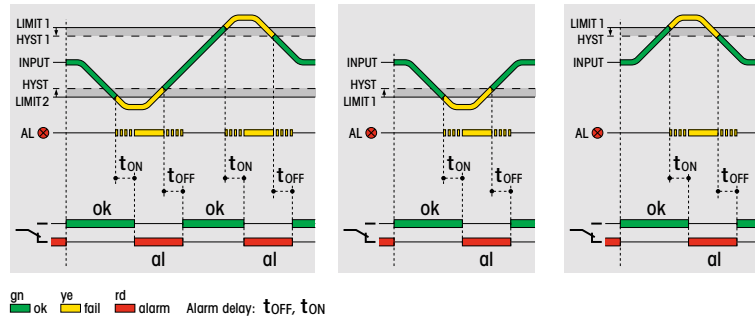

Measuring circuit data

Voltage setting ranges AC / DC	0 ... 480 V / 0 ... 690 V
Current setting ranges AC / DC	0 ... 5 A
Frequency	DC, AC 16 ... 100 Hz
Resolution U / I	100 mV / 100 mA
Accuracy	2 % ± 1 digit
Input resistance U / I	1 MΩ / 5 mΩ

Time data

Alarm delay setting time	0.1 ... 999.9 s
Reset time setting range	0.1 ... 999.9 s
Voltage failure buffering	ca. 30 ms

Contacts

Type / Material	1 CO / AgNi 0.15
Rated operational current	6 A
Max. inrush current	15 A
Max. switching voltage	250 V
Max. AC load AC-1 (Fig.1)	1250 VA
Max. DC load DC-1, 24 V / 220 V (Fig.2)	120 W / 25 VA
Recommended min. contact load	10 mA / 10 V

Power supply

	UC12-48V	UC110-240V
Nominal voltage AC/DC	12 ... 48 V	110 ... 240 V
Operating voltage range	10 ... 57 V	85 ... 250 V
AC frequency	16 ... 63 Hz	16 ... 63 Hz
Power consumption	2 W / 3 VA	2 W / 3 VA

Insulation

Test voltage open - contact	1 kVrms 1 minute
Test voltage measuring input - contacts	4 kVrms 1 minute
Test voltage measuring input - power supply	4 kVrms 1 minute

General specifications

Ambient temperature storage /operation	-40 ... +85 °C / -25 ... +60 °C
Mechanical life of contacts	30 x 10 ⁶ operations
Conductor cross section	Stranded wire 2.5 mm ² , 2 x 1.5 mm ²
Ingress protection rating	IP20
Max. screw torque	0.4 Nm
Housing material	Lexan EXL 9330
Weight	130 g

Standard types

UC 12-48 V (AC/DC), 15...60 Hz
UC 110-240 V (AC/DC), 15...60 Hz

MRM11R/UC12-48V
MRM11R/UC110-240V

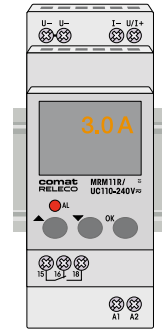

Connection diagram

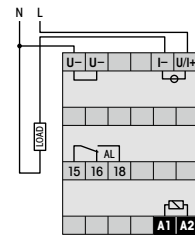

Fig. 1 AC voltage endurance

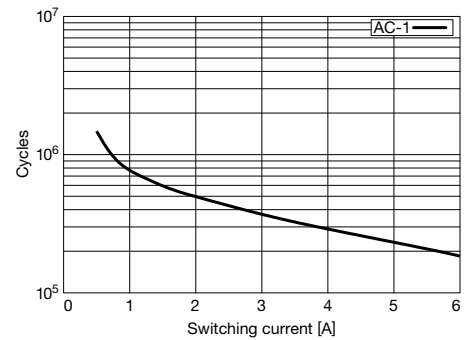
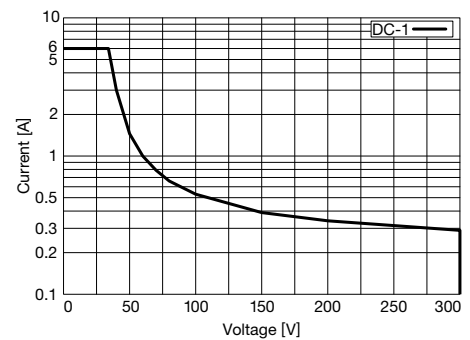
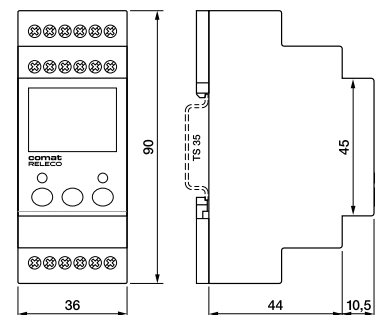

Fig. 2 DC load limit curve



Dimensions [mm]



Technical approvals, conformities

See table on page 53.

MRM32R

Multifunction monitoring relay AC/DC, three phase DIN Rail mounting according to DIN 43 880

Type: MRM32R/...V

Multifunctional monitoring relay for simultaneous measurement of current and voltage and monitoring of U, I, P, cosφ and f and Δφ. Alarm delay setting. Alarm LED. Display for multimeter function, alarm signal and interactive parameter setting.

2 change-over alarm contacts 6 A 250 V. Comfortable parameter setting.

Monitoring function

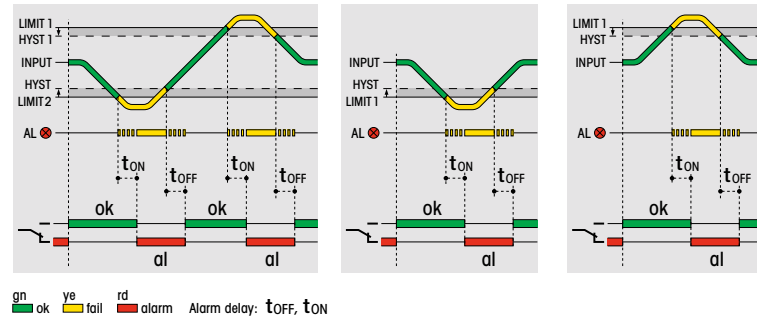

Measuring circuit data

Voltage setting ranges AC / DC	0 ... 480 V / 0 ... 690 V
Current setting ranges AC / DC	0 ... 5 A
Frequency	DC, AC 16 ... 100 Hz
Resolution U / I	100 mV / 100 mA
Accuracy	2 % ±1 digit
Input resistance U / I	1 MΩ / 5 mΩ

Time data

Alarm delay setting time	0.1 ... 999.9 s
Reset time setting range	0.1 ... 999.9 s
Voltage failure buffering	ca. 30 ms

Contacts

Type / Material	2 CO / AgNi 0.15
Rated operational current	6 A
Max. inrush current	15 A
Max. switching voltage	250 V
Max. AC load AC-1 (Fig.1)	1250 VA
Max. DC load DC-1, 24 V / 220 V (Fig.2)	120 W / 25 W
Recommended min. contact load	10 mA / 10 V

Power supply

	UC 12-48V	UC 110-240V
Nominal voltage AC/DC	12 ... 48 V	110 ... 240 V
Operating voltage range	10 ... 57 V	85 ... 250 V
AC frequency	16 ... 63 Hz	16 ... 63 Hz
Power consumption	2 W / 3 VA	2 W / 3 VA

Insulation

Test voltage open - contact	1 kVrms 1 minute
Test voltage between poles	2.5 kVrms 1 minute
Test voltage measuring input - contacts	4 kVrms 1 minute
Test voltage measuring input - power supply	4 kVrms 1 minute

General specifications

Ambient temperature storage /operation	-40 ... +85 °C / -25 ... +60 °C
Mechanical life of contacts	30 x 10 ⁶ operations
Conductor cross section	Stranded wire 2.5 mm ² , 2 x 1.5 mm ²
Ingress protection rating	IP20
Max. screw torque	0.4 Nm
Housing material	Lexan EXL 9330
Weight	130 g

Standard types

UC 12-48 V (AC/DC), 15...60 Hz
UC 110-240 V (AC/DC), 15...60 Hz

MRM32R/UC12-48V
MRM32R/UC110-240V

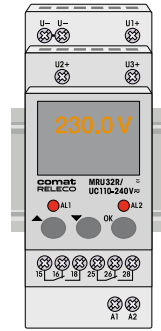

Connection diagram

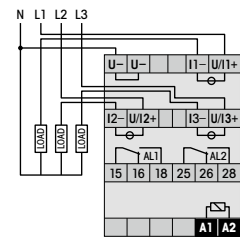

Fig. 1 AC voltage endurance

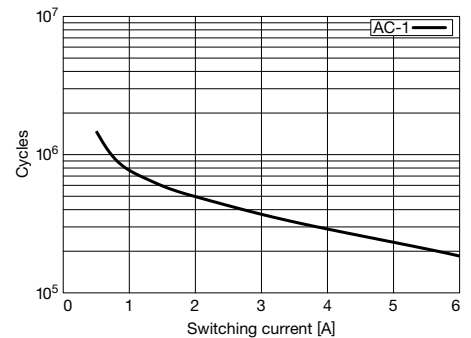
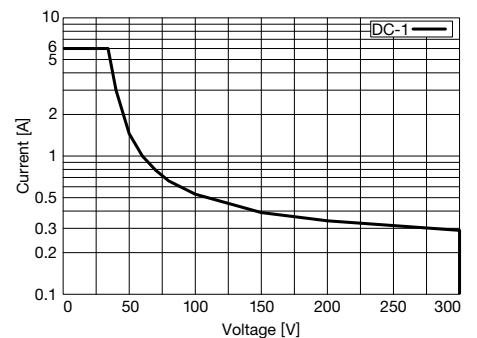
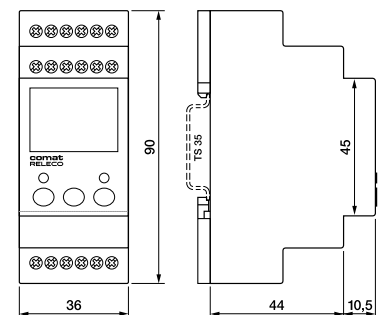

Fig. 2 DC load limit curve



Dimensions [mm]



Technical approvals, conformities

See table on page 53.

CT512R, CT515R, CT516R

Plug-in current monitoring module; 0.2 A, 2 A, 6 A. DC 24 V operation

Type: CT512R, CT515R, CT516R /... V

Plug-in current monitoring modules for sockets with module slot in combination with plug-in relays. DC 24 V operation. LED alarm state indicators for OK and fail. Separate adjustment of upper and lower level.

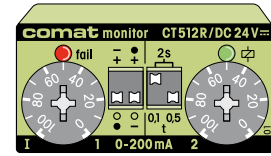

Monitoring functions

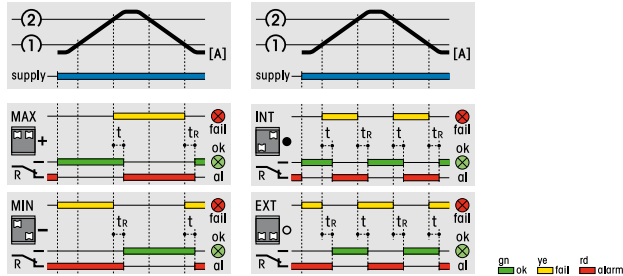

Over / under voltage internal / external range

Measuring circuit data

Type	CT512R	CT515R	CT516R
Measuring and setting ranges (rotary knobs)	0 ... 200 mA	0 ... 2 A	0 ... 6 A
Max. current 100% duty cycle	300 mA	3 A	7 A
Voltage drop on internal shunt res. @ I _{max}	300 mV	200 mV	100 mV
Temperature drift -25 ... 60 °C	≤ 3 %	≤ 3 %	≤ 3 %

Time data

Alarm delay time settings	100 ms, 500 ms, 2 s
Reset time	100 ms

Power supply

	DC 24 V	DC 36 V
Nominal voltage	18 ... 30 V	18 ... 45 V
Operation voltage range	3 ... 7 mA	5 mA
Supply current	- 30 V	- 51 V
Polarity reversal protection		

General specifications

Ambient temperature storage/operation	-40 ... +85 °C / -40 ... +70 °C
Ingress protection rating	IP 40 when plugged in
Housing material	Lexan
Weight	25 g

Standard types

CT512R	CT512R/DC24V	CT512R/DC36V
CT515R	CT515R/DC24V	CT515R/DC36V
CT516R	CT516R/DC24V	CT516R/DC36V

Remark: This module is part of several ready for connection units consisting of socket, relay and module.
A wide variety of suitable relays is available.

Connection diagram

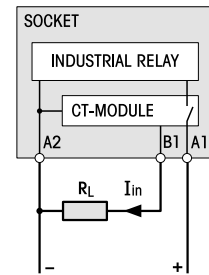

Dimensions [mm]

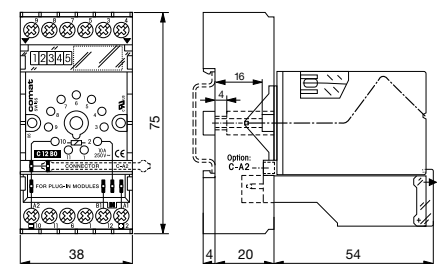

Technical approvals, conformities

See table on page 53.

CT524R, plug-in DC voltage monitoring module

Plug-in DC voltage monitoring module

Type: CT524R/...V

Plug-in DC voltage monitoring module for sockets with module slot in combination with 11p plug-in relays. DC 24 V operation. LED alarm state indicators for OK and fail. Separate adjustment of upper and lower level.

Monitoring functions

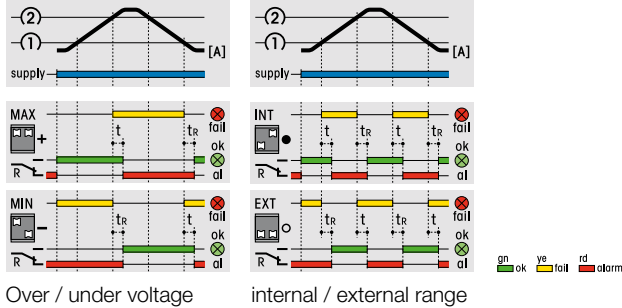

Over / under voltage internal / external range

Measuring circuit data

Type	CT524R
Measuring and setting ranges (rotary knobs)	0 ... 30 V
Over voltage (10 ms)	± 150 V
Input resistance	106 kΩ
Temperature drift -25 ... 60 °C	≤ 2 %

Time data

Alarm delay time settings	100 ms, 500 ms, 2 s
Reset time	100 ms

Power supply

Nominal voltage	DC 24 V
Operation voltage range	18 ... 30 V
Supply current	8 ... 13 mA
Polarity reversal protection (1 minute)	- 30 V

General specifications

Ambient temperature storage/operation	-40 ... +85 °C / -40 ... +70 °C
Ingress protection rating	IP 40 when plugged in
Housing material	Lexan
Weight	25 g

Standard types

CT524R	CT524R/DC24V
---------------	---------------------

Remark: This module is part of several ready for connection units consisting of socket, relay and module.
A wide variety of suitable relays is available.

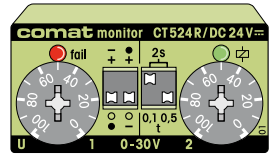

Connection diagram

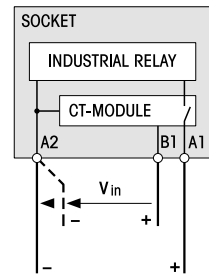

Dimensions [mm]

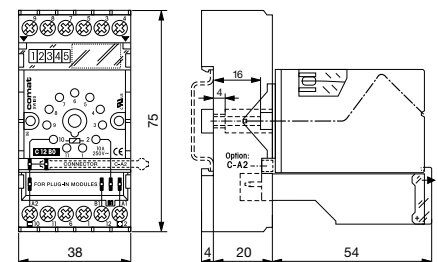

Technical approvals, conformities

See table on page 53.

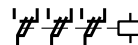
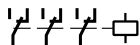

DC Voltage Monitoring-Set
DC Current Monitoring-Set

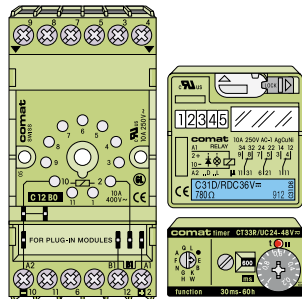

Set-Delivery includes:

- Relay
- Module
- Front cover
- Socket
- Retaining clip

Relay data's see:
Section Industrial Relays

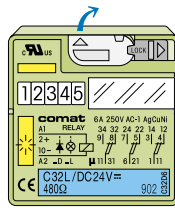

C31L

Universal Power Relay 10A
with 3 power change-over-contacts this is the robust relay for AC and DC circuits ranging from 50mA 10V.

10A 250V~
50mA 10V

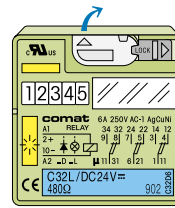

C32L

Relay with 3 twin contacts 6A
The control relay with highest switching reliability for control and signal circuits ranging from 10mA 5V.

6A 250V~
10mA 5V

Monitoring Module

4 functions can be selected: Overvoltage / undervoltage monitoring with adjustable hysteresis or 2 range monitors (INT or EXT). Adjustable alarm delay. LED display for errors and ok. Contact inspection window at the top. Manual safety operation.

Module see page 40/41

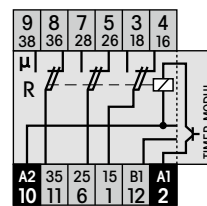
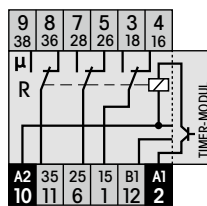

CT524
DC Voltage Monitoring

Range: **0-30V**
Umax: **40V**

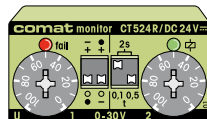

Triggering

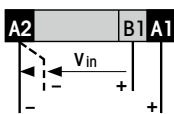

Input resistance
B1 → A2: 100kΩ

Set Order-Nr.:

CT524.31R/24V

- Delivery includes:
- Relay C31D/R DC24V
 - Module CT524R/DC24V
 - Front cover FS-C
 - Socket C12B0
 - Retaining clip HF-32

Set Order-Nr.:

CT524.32R/24V

- Delivery includes:
- Relay C32D/R DC24V
 - Module CT524R/DC24V
 - Front cover FS-C
 - Socket C12B0
 - Retaining clip HF-32

CT512
DC Current Monitoring

Range: **0-200mA**
Imax: **300mA**

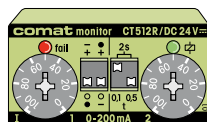

Triggering

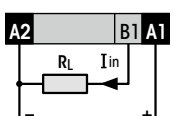

Voltage drop
A1 → B1 ≤ 300mV

Set Order-Nr.:

CT512.31R/...V
DC 24, 36V

- Delivery includes:
- Relay C31D/R DC...V
 - Module CT512R/DC...V
 - Front cover FS-C
 - Socket C12B0
 - Retaining clip HF-32

Set Order-Nr.:

CT512.32R/...V
DC 24, 36V

- Delivery includes:
- Relay C32D/R DC...V
 - Module CT512R/DC...V
 - Front cover FS-C
 - Socket C12B0
 - Retaining clip HF-32

CT515
DC Current Monitoring

Range: **0-2A**
Imax: **3A**



Triggering

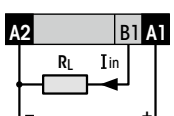

Voltage drop
A1 → B1 ≤ 200mV

Set Order-Nr.:

CT515.31R/...V
DC 24, 36V

- Delivery includes:
- Relay C31D/R DC...V
 - Module CT515R/DC...V
 - Front cover FS-C
 - Socket C12B0
 - Retaining clip HF-32

Set Order-Nr.:

CT515.32R/...V
DC 24, 36V

- Delivery includes:
- Relay C32D/R DC...V
 - Module CT515R/DC...V
 - Front cover FS-C
 - Socket C12B0
 - Retaining clip HF-32

CT516
DC Current Monitoring

Range: **0-6A**
Imax: **7A**

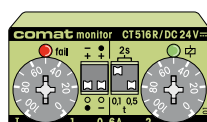

Triggering

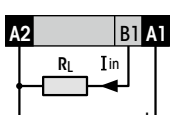

Voltage drop
A1 → B1 ≤ 100mV

Set Order-Nr.:

CT516.31R/...V
DC 24, 36V

- Delivery includes:
- Relay C31D/R DC...V
 - Module CT516R/DC...V
 - Front cover FS-C
 - Socket C12B0
 - Retaining clip HF-32

Set Order-Nr.:

CT516.32R/...V
DC 24, 36V

- Delivery includes:
- Relay C32D/R DC...V
 - Module CT516R/DC...V
 - Front cover FS-C
 - Socket C12B0
 - Retaining clip HF-32

Dimensions [mm]

See page 40.

Technical approvals, conformities

See table on page 53.

ESU-D2R

Insulation monitoring relay for unearthed DC-networks DIN Rail mounting

Type: ESU-D2R/UC24V

Earth insulation resistance monitoring relay

Pre alarm 1 CO and main alarm 1 NO + 1 CO contact outputs 5 A / 250 V

UC 24 ... 48 V, operating voltages, monitoring of DC 12 ... 48 V power supply networks.

Monitoring of earth interruption on the device.

The device measures single or combined resistances occurring against + or - pole of the DC network. Adjustable alarm delay. Proved reliability in rolling stock applications.

Monitoring function

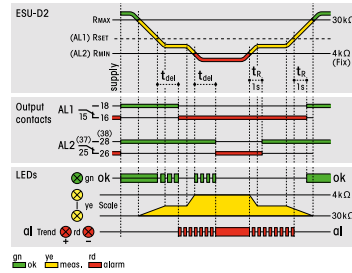

The ESU-D2 monitors the isolation resistance in non-grounded DC-networks (24 – 48 V).

Two alarm steps (prealarm AL1 and main alarm AL2) are indicated via separate output contacts.

Displays: bargraph-display of the measured earthing resistance (green = ok). Two red LEDs show the ground tendency towards plus (+) or minus (-).

Output terminals 5 V for the external display of the earthing resistance (0,1 V/kΩ).

Test functions: Periodic automatic check, also with key "Test".

Environmental failures: monitoring of AC-short circuit, over-voltage, ground interruption.

Measuring circuit data

Measuring / setting range for pre alarm	1 ... 50 kΩ / 4 ... 30 kΩ
Constant value for main alarm	4 kΩ
Tolerance	≤ 10 %
Overvoltage alarm level of DC network	60 V
Input current + → -	≤ 5 mA
Sampling current pulses +/- → earth	0,2 mA
Overvoltage safety from earth to +/- poles	AC 250 V
Max. capacity +/- → earth	1,5 μF ¹⁾

¹⁾ Types for capacitances until 60 μF on request

Time data

Alarm delay time adjustment range	0,1 ... 10 s
Fault detection time	600 ms
Auto reset time, fail to OK	1 s

Contacts

Type / Material	2 CO, 1 NO micro disconnection / AgNi
Rated operational current / min. contact load	5 A / 1 mA 12 V
Max. switching voltage (Fig. 1)	250 V

Power supply

Nominal voltage	UC 24-48 V
Operation voltage range	16,8 ... 60 V
Power consumption	2 W
Voltage failure buffering	≥ 50 ms

Insulation

Test voltage contacts to other circuits	2 kVrms 1 minute
---	------------------

General specifications

Ambient temperature storage /operation	-40 ... +85 °C / -40 ... +70 °C
Ingress protection rating	Housing: IP 40, terminals: IP 20
Max. screw torque	0,5 Nm
Weight	250 g

Standard types

UC24-48 (AC/DC)

ESU-D2R/UC24-48V

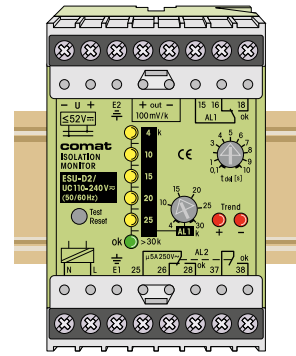

Connection diagram

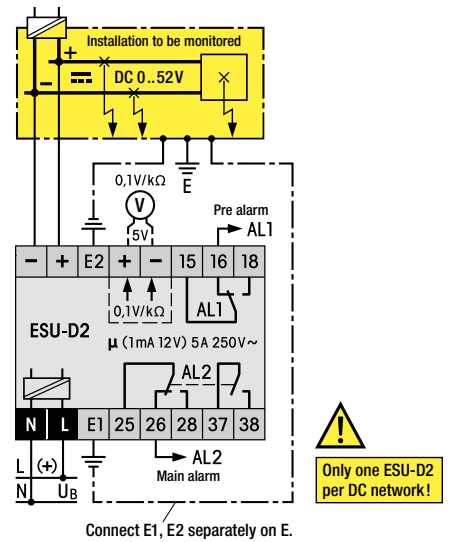
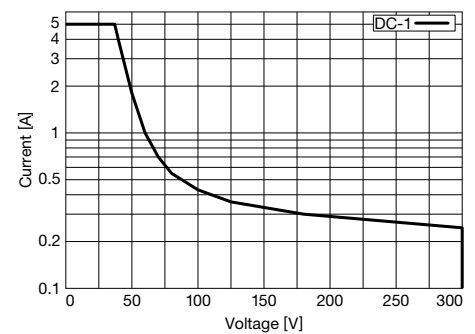
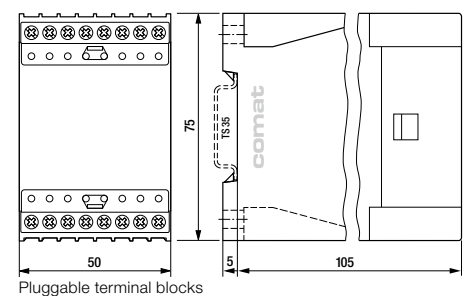

Fig. 2 DC load limit curve



Dimensions [mm]



Technical approvals, conformities

See table on page 53.

4. Sockets

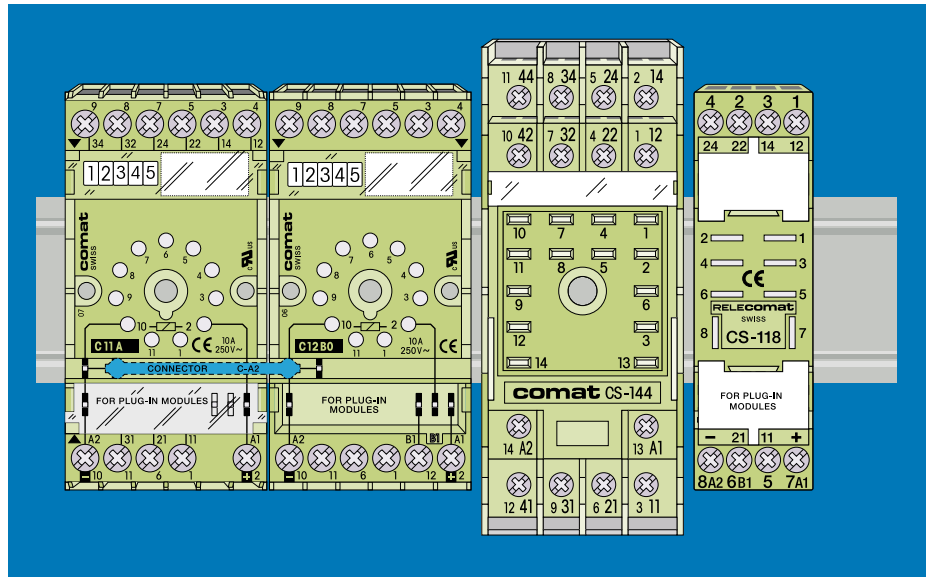

Application	Types	Rated load	Pins
Socket for 11 pin relays and plug-in modules	C11A	10A, 250V	
Socket for 11 pin relays and plug-in modules	C12B0	10A, 250V	
Socket for 14 pin relays	CS-144	10A, 250V	
Socket for miniature relays	CS-118	10A, 250V	

C11A

Socket for 11 pin plug-in relays C31D/R, C32D/R, R3-N3x and plug-in modules



Type: C11A

3-pole, 1 level

Module slot for over voltage suppressing and LED indicator modules, coil bridge bus bar to connect in A2

Rated current 10 A

Specifications

Rated load	10 A
Insulation	Test voltage V_{rms} / 1 min
- All terminals/DIN rail	2.5 kV
- Terminal/terminal	2.5 kV
Cross-section of connecting wire	
- Multi-wire	1 x 4 mm ² , 2 x 2.5 mm ²
Max. screw torque	0.7 Nm
Screw dimensions	M3, Pozi, slot
Labelling space	detachable
Connection label	1...11; DIN/EN
Mounting	DIN rail TS35 or panel mounting
Ambient temperature operation / storage	-40 (no ice) ... +70 °C / -40 ... +85 °C
Weight	56 g

Associated plug-in 11-pin relays C31D/R, C32D/R and R3-N3x

Type C11A

Accessories

Retaining springs, steel	HF-32 (Relays C31, C32) HF-33 (Timecube + Relays C31, C32) S3-C (Relays R3-N3x)
Coil bridge bus bar	C-A2
Marking strip cardboard white 8 x 16	L-16/5 (under transp. plastic cover)
Illuminated display	RL1/...
Suppressing unit	RC1/... RCL1/... RD1/...

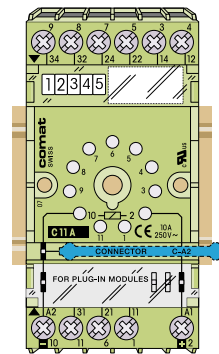

Connection diagram

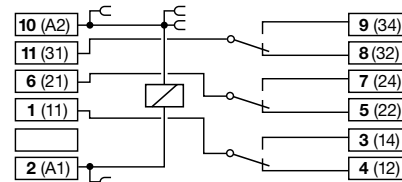

Dimensions [mm]

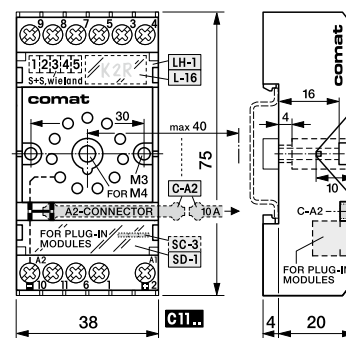

Technical approvals, conformities

See table on page 53.

C12B0

Socket for 11 pin plug-in relays C31D/R, C32D/R, R3-N3x and plug-in control modules

Type: C12B0

3-pole, 1 level
 Module slot for timer- and monitoring modules, over voltage suppressing and LED indicator modules
 coil bridge bus bar to connect in A2

Rated current **10 A**

Specifications

Rated load	10 A
Insulation	Test voltage V_{rms} / 1 min
– All terminals/DIN rail	2.5 kV
– Terminal/terminal	2.5 kV
Cross-section of connecting wire	
– Multi-wire	1 x 4 mm ² , 2 x 2.5 mm ²
Max. screw torque	0.7 Nm
Screw dimensions	M3, Pozi, slot
Labelling space	detachable
Connection label	1...12; DIN/EN
Mounting	DIN rail TS35 or panel mounting
Ambient temperature operation / storage	-40 (no ice) ... +70 °C / -40 ... +85 °C
Weight	61 g

Associated plug-in 11-pin relays **C31D/R, C32D/R and R3-N3x**

Type **C12B0**

Accessories

Retaining springs, steel	HF-32 (Relays C31, C32) HF-33 (Timecube + Relays C31, C32) S3-C (Relays R3-N3x)
Coil bridge bus bar	C-A2
Marking strip cardboard white 8 x 16	L-16/5 (under transp. plastic cover)
Illuminated display	RL1/...
Suppressing unit	RC1/... RCL1/... RD1/...

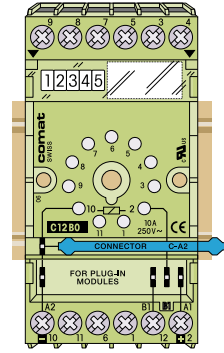

Connection diagram

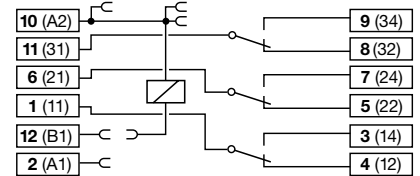

Dimensions [mm]

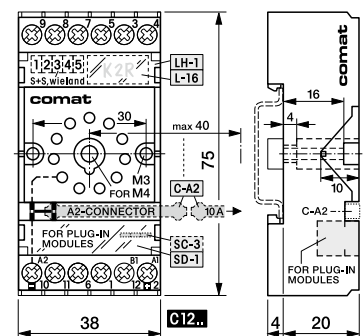

Technical approvals, conformities

See table on page 53.

CS-144

Socket for 14-pin plug-in relays R4-Ax

Type: CS-144

4-pole, 2 connection level
Integrated retaining clip and labelling space

Rated current **10 A**

Specifications

Rated load	10 A / 250 V
Insulation	Test voltage V_{rms} / 1 min
- All terminals/DIN rail	2.5 kV
- Terminal/terminal	2.5 kV
Cross-section of connecting wire	
- Single-wire	4 mm ² or 2 x 2.5 mm ²
- Multi-wire	22 - 14 AWG
Max. screw torque	1 Nm
Screw dimensions	M3.5, Pozi, slot
Integrated retaining clip/plastic	for relay series C4
Labelling space	detachable
Connection label	1...14; DIN/EN
Mounting	DIN rail TS35 or panel mounting
Ambient temperature operation / storage	-40 (no ice) ... +70 °C / -40 ... +80 °C
Weight	80 g

Associated, plug-in 14-pin relays **R4-A4x**

Type **CS-144**

Accessories

Retaining spring, steel	S4-C
Retaining clip, plastic	S3-CMG

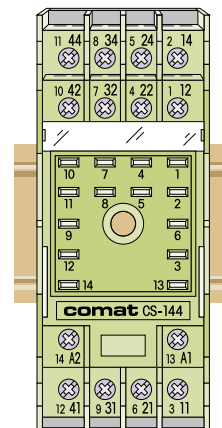

Connection diagram

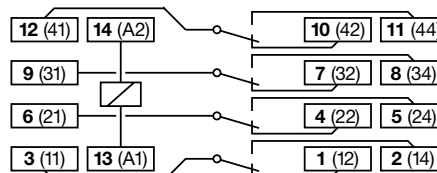

Dimensions [mm]

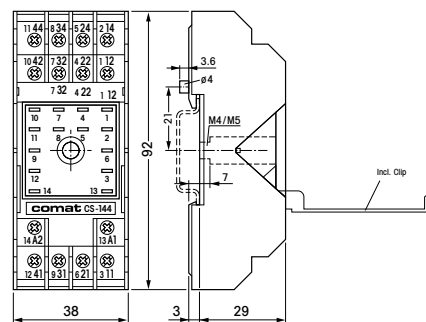

Technical approvals, conformities

See table on page 53.

CS-118

Socket for miniature plug-in relays R7-A, R7-T

Type: CS-118

2-pole, 1 level
integrated clip and marking label
suitable for C80 series time relays with clip
coil bridge bus bar to connect in A2
plug-in slot for overvoltage suppressing units

Rated current **10 A**

Specifications

Rated load	10 A / 250 V
Insulation	Test voltage Vrms / 1 min
– All terminal/DIN rail	2.5 kV
– Terminal/terminal	2.5 kV
Cross section of connecting wire	
– Single wire	4 mm ² , 2 x 1.5 mm ²
– Multi wire	2.5 mm ² / AWG 16, 2 x 1 mm ² / AWG 18
Max. screw torque	0.7 Nm
Screw dimensions	M3, Pozi, slot
Integrated retaining clip/plastic	for relays C7
Labelling space	detachable
Connection label	1...8, DIN/EN
Mounting	DIN rail TS35 or panel mounting
Ambient temperature operation / storage	-40 (no ice) ... +70 °C / -40 ... +80 °C
Weight	37 g

Associated plug-in 8-pin relays **R7-A, R7-T**

Type **CS-118**

Accessories

Coil bridge bus bar	S7-B
Retaining clip, plastic	RC-G

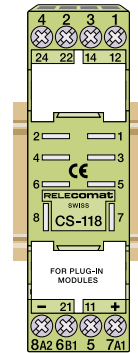

Connection diagram

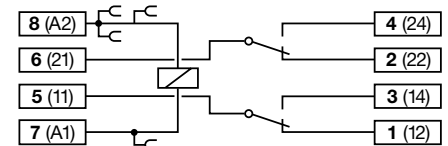

Dimensions [mm]

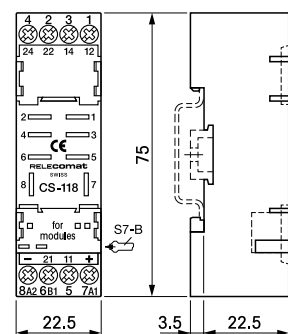

Technical approvals, conformities

See table on page 53.

Technical approvals, conformities

Type	EN 50155						EN 61373	NF F 16-101/102		EN 45545-2		UL	
	Temperature rating	Power supply				Protective coating PCB	Schock & vibrations test	Smoke gas index F	Inflammability I	R23	R24	Listed	
		S1	S2	C1	C2								
Relays													
C31D/R	TX	YES	YES	YES	NO	N/A	Category 1, Class B	F2	I3			E120922	
C32D/R	TX	YES	YES	YES	NO	N/A	Category 1, Class B	F2	I3			E120922	
R3-N3...	T3	YES					Category 1, Class B						
R4-A4...	T1	YES	Approval in process										
R7-A2...	T3	YES					Category 1, Class B						
R7-T2...	T3	YES					Category 1, Class B						
C203.6R	TX	YES	YES	YES	NO	YES	Category 1, Class B	F2	I3	HL2	HL2		
CINT-21	TX	YES	NO	YES	NO	NO	Category 1, Class B	F2	I3	HL2	HL2		
CINT-22	TX	YES	NO	YES	NO	NO	Category 1, Class B	F2	I3	HL2	HL2		
CINT-25	T2	YES	NO	YES	NO	NO	Category 1, Class B	F2	I3	HL2	HL2		
CINT-61	TX	YES	NO	YES	NO	NO	Category 1, Class B	F2	I3	HL2	HL2		
CINT-62	TX	YES	NO	YES	NO	NO	Category 1, Class B	F2	I3	HL2	HL2		
CINT-63	TX	YES	NO	YES	NO	NO	Category 1, Class B	F2	I3	HL2	HL2		
Time relays													
RIC20-...		YES	YES	YES	NO	NO	In approval						
RIC25-...		YES	YES	YES	NO	NO	Category 1, Class B						
CIM1R	TX	YES	YES	YES	YES	YES	Category 1, Class B	F2	I3	HL2	HL2		
CIM12R	TX	YES	YES	YES	YES	YES	Category 1, Class B	F2	I3	HL2	HL2		
CIM13R	TX	YES	YES	YES	YES	YES	Category 1, Class B	F2	I3	HL2	HL2		
CIM2R	TX	YES	YES	YES	YES	YES	Category 1, Class B	F2	I3	HL2	HL2		
CIM22R	TX	YES	YES	YES	YES	YES	Category 1, Class B	F2	I3	HL2	HL2		
CIM23R	TX	YES	YES	YES	YES	YES	Category 1, Class B	F2	I3	HL2	HL2		
CIM3R	TX	YES	YES	YES	YES	YES	Category 1, Class B	F2	I3	HL2	HL2		
CIM32R	TX	YES	YES	YES	YES	YES	Category 1, Class B	F2	I3	HL2	HL2		
CIM33R	TX	YES	YES	YES	YES	YES	Category 1, Class B	F2	I3	HL2	HL2		
CT32R (modul)	TX	YES	YES	YES	NO	YES	Category 1, Class B	F2	I3	HL2	HL2		
CT32.31R (set)	TX	YES	YES	YES	NO	YES	Category 1, Class B	F2	I3				
CT32.32R (set)	TX	YES	YES	YES	NO	YES	Category 1, Class B	F2	I3				
CT33R (modul)	TX	YES	YES	YES	NO	YES	Category 1, Class B	F2	I3	HL2	HL2		
CT33.31R (set)	TX	YES	YES	YES	NO	YES	Category 1, Class B	F2	I3				
CT33.32R (set)	TX	YES	YES	YES	NO	YES	Category 1, Class B	F2	I3				
CT36R (modul)	TX	YES	YES	YES	NO	YES	Category 1, Class B	F2	I3	HL2	HL2		
CT36.31R (set)	TX	YES	YES	YES	NO	YES	Category 1, Class B	F2	I3				
CT32.32R (set)	TX	YES	YES	YES	NO	YES	Category 1, Class B	F2	I3				
Monitoring relays													
CT512R (modul)	TX	YES	YES	YES	NO	YES	Category 1, Class B	F2	I3	HL2	HL2		
CT512.31R (set)	TX	YES	YES	YES	NO	YES	Category 1, Class B	F2	I3				
CT512.32R (set)	TX	YES	YES	YES	NO	YES	Category 1, Class B	F2	I3				
CT515R (modul)	TX	YES	YES	YES	NO	YES	Category 1, Class B	F2	I3	HL2	HL2		
CT515.31R (set)	TX	YES	YES	YES	NO	YES	Category 1, Class B	F2	I3				
CT515.32R (set)	TX	YES	YES	YES	NO	YES	Category 1, Class B	F2	I3				
CT516R (modul)	TX	YES	YES	YES	NO	YES	Category 1, Class B	F2	I3	HL2	HL2		
CT516.31R (set)	TX	YES	YES	YES	NO	YES	Category 1, Class B	F2	I3				
CT516.32R (set)	TX	YES	YES	YES	NO	YES	Category 1, Class B	F2	I3				
CT524R (modul)	TX	YES	YES	YES	NO	YES	Category 1, Class B	F2	I3	HL2	HL2		
CT524.31R (set)	TX	YES	YES	YES	NO	YES	Category 1, Class B	F2	I3				
CT524.32R (set)	TX	YES	YES	YES	NO	YES	Category 1, Class B	F2	I3				
MRI11R		Approval in process											
MRI32R		Approval in process											
MRM11R		Approval in process											
MRM32R		Approval in process											
MRU11R		Approval in process											
MRU32R		Approval in process											
ESU-D2R	TX	YES	YES	YES	YES	YES	Category 1, Class B	F2	I3				
Sockets													
C11A	TX	N/A	N/A	N/A	N/A	N/A	Category 1, Class B	F2	I3	HL2	HL2	E120922	
C12B0	TX	N/A	N/A	N/A	N/A	N/A	Category 1, Class B	F2	I3	HL2	HL2	E120922	
CS-118	TX	N/A	N/A	N/A	N/A	N/A	Approval in process	F2	I3	HL2	HL2	E196531	
CS-144	TX	N/A	N/A	N/A	N/A	N/A	Category 1, Class B	F2	I3	HL2	HL2	E196531	



COMAT AG • BERNSTR. 4
CH-3076 WORB
TEL. +41 (0)31 838 55 77
FAX +41 (0)31 838 55 99
www.comat.ch • info@comat.ch